

THESIS FOR THE DEGREE OF LICENTIATE OF ENGINEERING

**Catalytic tar cleaning of biomass-derived gas with simultaneous catalyst
regeneration**

Fredrik Lind

Department of Energy and Environment
CHALMERS UNIVERSITY OF TECHNOLOGY
Göteborg, Sweden 2011

Catalytic tar cleaning of biomass-derived gas with simultaneous catalyst regeneration

Fredrik Lind

© Fredrik Lind 2011

Department of Energy and Environment

Division of Energy Technology

Chalmers University of Technology

SE-412 96 Gothenburg

Sweden

Telephone + 46 (0)31-772 1000

Printed in Sweden

Chalmers Reproservice

Göteborg 2011

Catalytic tar cleaning of biomass-derived gas with simultaneous catalyst regeneration

Fredrik Lind

Department of Energy Technology
Chalmers University of Technology
SE-412 96 Gothenburg (Sweden)

Abstract

Tar cleaning of raw gas from biomass gasification is a necessary operation before the gas can be used as feedstock for synthetic fuels. The technology for gas cleaning that is commercially available today (scrubber systems), is associated with problems like heat penalties and loss of the chemically stored energy within the tars. These problems are addressed in this work, and a novel method for secondary tar cleaning is proposed and experimentally validated. The method is applicable to all types of biomass gasifier and regardless of whether primary measures for tar reduction are used or not. The tar cleaning system can be thermally integrated with the gasifier outlet temperature, which leads to minimal heat losses. The method combines tar cleaning with catalyst regeneration in a system of dual fluidized beds, which in this work is experimentally explored in two identically sized reactors systems: a cold Perspex unit and a high temperature steel unit. Fluid dynamics and operation controllability was evaluated in the cold system, where the results indicated that the solid circulation is controllable and sufficient gas tightness of the loop-seals could be achieved.

The gained knowledge from operating the cold system was then used to demonstrate the tar cleaning method in the hot reactor system. This was done by using raw gas from Chalmers biomass gasifier, which contained roughly $30 \text{ g}_{\text{tar}}/\text{Nm}^3_{\text{tar}}$. Tar reforming activity, catalyst regeneration and the potential for catalytically adjusting the raw gas was investigated with two different catalysts: (1) Ilmenite (Fe_2TiO_3), a naturally occurring ore with bulk price comparable to hard coal and, (2) Mn4MgZ1150, a synthetic manufactured catalyst consisting of 40 % Manganese oxide (Mn_3O_4) supported on 60 % Magnesium-Zirconium oxide (MgZrO_3). Experiments with 60 % ilmenite in silica sand and 23 % M4MgZ1150 in silica sand were performed. The result showed that the total amounts of tars were reduced by as much as 44.5 % in the M4MgZ1150 case and by 35 % in the ilmenite case. Both catalysts showed activity in Water-Gas Shift reaction and the H_2/CO ratio was shifted from 0.7 in the raw gas to 3 downstream of the reactor system for the ilmenite case and 0.6 to 1 in the manganese case.

Finally, an application for online monitoring of moisture content in a hot gas streams with rapid response time has been developed and experimentally investigated. The

idea is to replace the analogous weighting system for measuring the condensate water downstream of the tar cleaning reactor, which only gives a measurement in the time period of 5 – 10 min. In this work, the method is, however, experimentally tested in the 12 MW_{th} biomass fired CFB-boiler at Chalmers but, it can equally be used downstream of the tar cleaning reactor. The result showed that the application could detect moisture variations with a response time in the order of seconds. No sign of hysteresis was detected and very good precision in moisture content was achieved, with less than 4 % error after calibration.

Key words: Tar cleaning, Catalytic gas cleaning, Biomass gasification

List of Publications

- I. Fredrik Lind, Martin Seemann, Henrik Thunman. Evaluation of fluid dynamics in a hot and a cold system of interconnecting fluidized beds. In International conference on fluidization, Fluidization XIII, Gyeong-ju Korea, 2010; pp 869-876.
- II. Fredrik Lind, Martin Seemann, Henrik Thunman. Continuous tar cleaning of biomass derived raw gas with simultaneous catalyst regeneration. Submitted for publication
- III. Fredrik Lind, Mikael Israelsson, Martin Seemann, Henrik Thunman. Manganese oxide as catalyst for tar cleaning of biomass derived gas. Submitted for publication
- IV. Sven Hermansson, Fredrik Lind, Henrik Thunman. On-line Monitoring of Fuel Moisture-Content in Biomass-Fired Furnaces by Measuring Relative Humidity of the Flue Gases. Chem. Eng. Res. Des, 2010, doi:10.1016/j.cherd.2011.03.018

Fredrik Lind is the principle author of paper I, II and III. Sven Hermansson is the principle author of paper IV and Fredrik Lind made contributions to the design and construction of the measurement equipment and to the measurement work. Dr Martin Seemann is assistant academic supervisor and has organized and participated in the experimental work, he has also contributed with discussion and editing of paper I, II and III. Mikael Israelsson has contributed with evaluation of results in paper III. Prof Henrik Thunman is the principal academic supervisor and has contributed with discussion and editing paper I, II, III and IV.

Acknowledgment

First of all, I would like to express my gratitude to Henrik Thunman. Thank you for contributing with your never ending enthusiasm, sharing laughs and always dedicating time for supervision. Your sharpness and skills in the academic work are gratefully acknowledged. Martin Seemann your qualities are like the ones of a big brother, thank you for putting up with me, sharing your skills and being a good friend. Anton Larsson, Nicolas Berguerand and Mikael Israelsson thanks for creating the best working atmosphere. Sven Hermansson thanks for first-class cooperation in work as co-author and for good friendship.

We have a group of skillful research engineers which I would like to acknowledge: Jessica Bohwalli, Johannes Öhlin and Rustan Marberg. Special thanks are directed to Rustan for his work on the reactor and the auxiliary system. The boiler operating staff at Akademiska Hus: Per, Mikael, Raymond, Robert and Malin are acknowledged for their fingertip control for running the boiler and gasifier.

To all colleges at the division of energy technology thank you for being you!

Finally, I would like to thank my family and friends for being supporting. Lotta, Oskar and Gustav you are my everything and I love you truly!

This work has been financially supported through the Era-Net program and by E.On. The operation of the gasifier was made possible by grants from Göteborg Energi, Metso, Akademiska Hus and the Swedish Energy Agency. KTH are acknowledged for the tar analysis.

Fredrik Lind
Göteborg 2011

Table of Contents

1 - Introduction	1
2 - Tar cleaning techniques	5
2.1 Tar cleaning by Chemical Looping Reforming.....	8
2.2 Catalysts	9
3 - Methodology	11
3.1 Cold System investigations.....	11
3.2 Hot System investigations.....	14
3.3 Development of online water measurement	16
4 - Results and discussion	19
4.1 Cold system	19
4.2 Hot system	21
4.3 Development of online water measurement	26
5 - Conclusions	27
6 - Notations	29
7 - References	31

1 - Introduction

Potential routes for reducing emissions of carbon dioxide are frequently discussed in society today. Alternative energy from so called CO₂ neutral fuels that originates from biomass, preferably from lignocelluloses, has been introduced as possible candidates to tackle this emission issue. However, direct use of the energy stored in the native lignocelluloses with around 50 wt-% moisture content, is restricted solely to heat and power production. More complex processes are needed if the biomass is to be converted into e.g. a fuel for gas turbines, Synthetic Natural Gas (SNG), or to a liquid fuel for transportation. One potential technique path for producing these types of fuels is gasification together with gas cleaning and fuel synthesis. Nevertheless, all the process steps are not yet fully mature to be commercialized and further development is necessary. The problems related to produce a clean gas with the proper gas composition for downstream fuel synthesis process are investigated in this work. Furthermore, a novel method for catalytic tar cleaning and gas conditioning with simultaneous catalyst regeneration is presented.

Gasification together with gas cleaning and fuel synthesis is a method that can be used to produce high quality fuels from lignocelluloses. A simplified schematic picture of the process is shown in **Fig 1** together with some potential fuel processes. The gasifier constitutes the first step, which here is illustrated by the Chalmers gasifier, **Fig 2**. The 2 – 4 MW_{th} biomass gasifier (4) is integrated with a 12 MW_{th} Circulating Fluidized bed Boiler (CFB) for district heating (1). The boiler is fired with biomass to heat the bed material, in this case silica sand. The hot sand is separated from the flue gases in the cyclone (2) and is transported to a particle distributor (3), while the flue gases are used for heat and steam production in the convection path of the boiler. The particle distributor can be fluidized in two ways: either all bed material is returning to the boiler (thus without entering the gasifier) or a part of the bed material is recirculated back to the boiler via the gasifier. In the gasifier, the hot bed material is mixed with biomass and steam in a bubbling fluidized bed and a raw gas is produced. A portion of the total char produced from the fuel is recirculated with the cooled bed material back to boiler, where it is burned together with the biomass fed to the boiler.

In addition to the major gas components produced from the fuel in the gasifier (H_2 , CO , CO_2 , CH_4 , H_2O and light hydrocarbons) unacceptable amounts of condensable hydrocarbons are formed [1-6]. These hydrocarbons are usually referred to as tars and consist mainly in 1 to 5-ring aromatic compounds along with oxygen and sulphur containing hydrocarbons [2, 3]. The tar components are problematic as they start to condense already at $350^\circ C$ [7]. Uncontrolled condensation of the tars leads to fouling of equipment downstream the gasifier. The field of applications for direct use of the raw gas from the gasifier is, therefore, limited. However, if the gas is kept above $350^\circ C$ the gas can be used directly or after removal of particles to substitute fossil gas and oil in industrial burners, **Fig 1**. The drawing in **Fig 1** illustrates how the need for gas cleaning and process equipment increases as the raw gas is refined from a low to a high grade fuel. If the gas cleaning is further upgraded to remove tars as well, the gas can be used as fuel in modified internal combustion engines and gas turbines or even in the local gas grid. Additional process steps are needed if the gas is to be used as feedstock for synthetic fuel production. For synthesis into for example SNG, the ratio of H_2/CO needs to be controlled and the gas needs to be cleaned from sulphur (to protect the catalyst from deactivation). If having recourse to more downstream processes the gas can be further refined to liquid fuels (Dimethyl Ether (DME), Methanol or Fisher-Tropsch Diesel (F-T Diesel)).

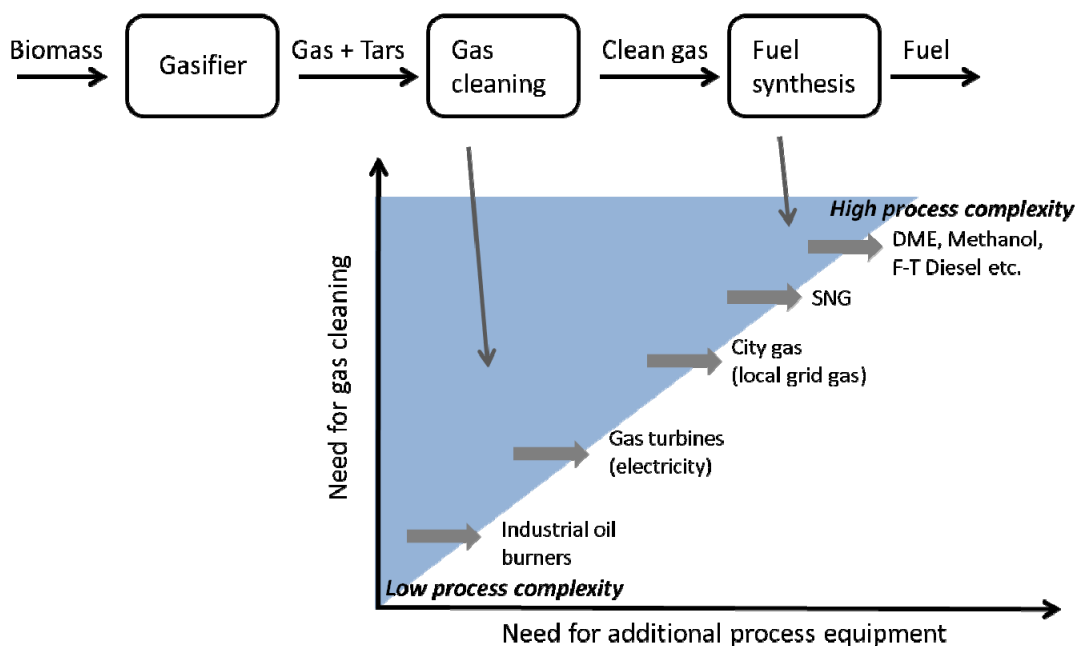

Figure 1 From lignocelluloses to gaseous fuels via gasification

The gasification technology is considered to have potential for large scale production of gas from biomass that could constitute a primary product for fuel production. Still today, there are no large scale lignocelluloses fuel synthesis plants in operation. One reason is a lack of cost efficient gas cleaning processes. The development of efficient

tar cleaning systems is, therefore, a crucial parameter before large scale fuel process via gasification can be commercialized.

Table 1 Reactions for tar cleaning and methanation

Operation	Chemical reaction	Nr	Heat of reaction
High temperature cleaning	$C_xH_y + H_2O \rightarrow nCO + (1+m/2)H_2$	(1)	Endothermic
	$CH_4 + H_2O \rightarrow CO + 3H_2$	(2)	Endothermic
Catalytic cleaning	$C_nH_m + H_2O \rightarrow C_iH_j + pCO + qH_2$	(3)	Exothermic/Endothermic
	$CO + H_2O \rightarrow H_2 + CO_2$	(4)	Exothermic
Methanation	$CO + 3H_2 \rightarrow CH_4 + H_2O$	(5)	Exothermic

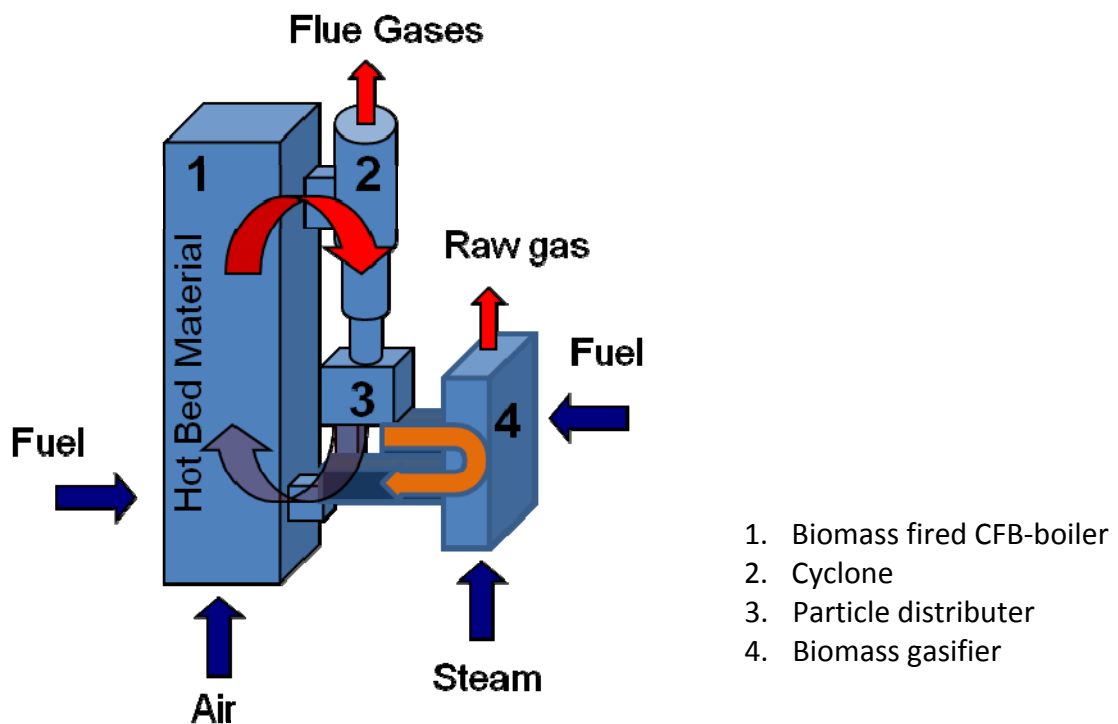

Figure 2 Chalmers boiler and gasifier system

2 - Tar cleaning techniques

Extensive work has been performed in the area of tar cleaning along with gas conditioning, and several approaches suitable for gas cleaning are reported in both literature [1, 8-11] and review papers [2, 4]. Tar cleaning of biomass producer gas can in principle be divided into two main groups; wet and dry cleaning. Wet cleaning is performed in scrubber units, where the tar is condensed on water or oil droplets during rapid cooling of the gas. The wet cleaning is commercialized and is today state-of-the-art technology. Dry cleaning is mostly referred to as catalytic or a high temperature cleaning (thermal cracking of tars). Catalytic cleaning can be integrated with the gasifier outlet temperature, whereas high temperature cleaning needs to be performed at elevated temperatures (>1100°C) to reach high conversion efficiencies [4]. Some of the product gas needs to be consumed to increase the exit temperature of the gasifier (from around 800 to 1100°C); this can be accomplished by adding oxygen to the product gas [4].

The path from native biomass to SNG, **Fig 1**, was selected as a reference process to compare the three techniques. **Figure 3** illustrates the operating temperatures for the three process steps. The gas cleaning step in **Fig 3** is divided into: high temperature cleaning, catalytic cleaning and cleaning by scrubber. The reactions (**table 1, reaction 1 and 2**) during high temperature cleaning are endothermic and all hydrocarbons including tars are broken down to CO and H₂. As production of SNG is the final target, the methane already formed in the gasification operation is cracked down during the high temperature cleaning.

Gas cleaning using scrubber technology is a well known method and the technique can be applied to tar cleaning of biomass producer gas. However, there is a large thermodynamic penalty as the gas is rapidly cooled from approximately 400°C to ambient temperature or even lower [9], **Fig 3**. Furthermore, the chemically bounded energy within the tars is lost. After the tars have been removed, the gas needs to be reheated to conduct the SNG synthesis (**table1, reaction 5**), which typically is performed at 200 - 450°C [12]. A significant expense related to the scrubber technology is the cost for fresh scrubber fluid and the cost for managing the spent one.

Catalytic tar cleaning is seen as the most promising method among the three techniques, as it shows the highest perspectives for heat integration with the gasifier and possibilities to recover the chemically stored energy within the tars. The technique can be conducted as primary or secondary cleaning. Primary cleaning involves catalysts already in the gasification step itself in order to promote cracking of tars [2]. This way, the tar cleaning and gasification reactions take place at the same temperature. The method is, therefore, less flexible towards optimization of the tar cleaning, in comparison to secondary tar cleaning which can be optimized independently of the gasifier operating properties [4], **Fig 3**. Secondary tar cleaning can be summarized by means of three features: 1) catalyst reactor temperatures are thermally integrated with the gasifier outlet, 2) steam can be added to ensure complete reforming of the tars (**table 1, reaction 3**) and 3) the composition of the product gas can be catalytically adjusted (**table 1, reaction 4**) [4]. This means, that it is possible to control the ratio of hydrogen and carbon monoxide for methanation already in the tar cleaning step and, hence, the gas conditioning step in the SNG synthesis would become redundant.

It has been shown that the high tar content in biomass producer gas initiates carbon formation on the catalytic surfaces, causing severe deactivation of the catalyst [2, 4, 9]. Several approaches to minimize the tendency to form carbon on the surface of the catalyst are reported in the literature surveyed. For example, catalyst deactivation as a result of carbon deposits was compared by Baker et al. in terms of fixed and fluidized beds for secondary tar cleaning [13]. They found that carbon deposits and catalyst deactivation was significantly lower on the catalysts in the fluidized bed. In parallel with secondary catalytic tar cleaning, Seemann et al reported that the internal catalyst circulation in a fluidized bed for methanation contributed in keeping the catalyst free of carbon deposits [12]. The methanation experiments showed that carbon deposits were formed on the catalyst in the bottom zone of the bed and as the catalyst was transported upwards in the bed, the carbon deposits were removed by hydrogenation and gasification reactions with water steam. Miyazawa et al. reported a lower carbon yield on various nickel catalysts during partial oxidation than during steam reforming [14]. This phenomenon can be explained by carbon combustion with O₂ during the catalyst fluidization. These problems of carbon formation on catalysts during reformation of hydrocarbons are well-known from the oil industry. A process dealing with these problems with both the conversion of hydrocarbons and formation of carbon on active surfaces is Fluid Catalytic Cracking (FCC). FCC which is performed in a dual fluidized bed to increase petrol yield in the refinery industry [15], **Fig 4**. In FCC reactors, the problem of carbon formation from cracking higher hydrocarbons is tackled by continuous regeneration of the catalyst surfaces, in this case a zeolite. The catalyst regeneration is performed in an air fed reactor, where the heat released from oxidation of the carbon deposits is transferred to the endothermic cracking reactor, **Fig 4**.

In this work, a new method for secondary catalytic tar cleaning is demonstrated based on the experience of the FCC technology. The tar cleaning is performed in a dual fluidized bed reactor system that simultaneously removes carbon deposits on the catalyst surfaces, even at high tar contents. The object is to break down the tar components to useful gas molecules by allowing the tar containing producer gas react with circulating partially oxidized catalysts in a tar reformer reactor. Oxygen from the catalyst is consumed in the tar reforming reactions and thereby produces a reduced catalyst. The catalyst is then re-oxidized and regenerated from carbon deposits in an air-fed oxidizing reactor followed by circulation back to the tar reforming reactor. The proposed tar cleaning method share several features with the FCC system, such as: catalytic treatment of hydrocarbons by a circulating catalyst, the regeneration of spent catalysts in air and the fact that heat from the regenerator can be transferred to the hydrocarbon reactions. However, the major difference is the opportunity for active molecule transport within the proposed method. The tar cleaning method has therefore been named Chemical Looping Reforming (CLR)

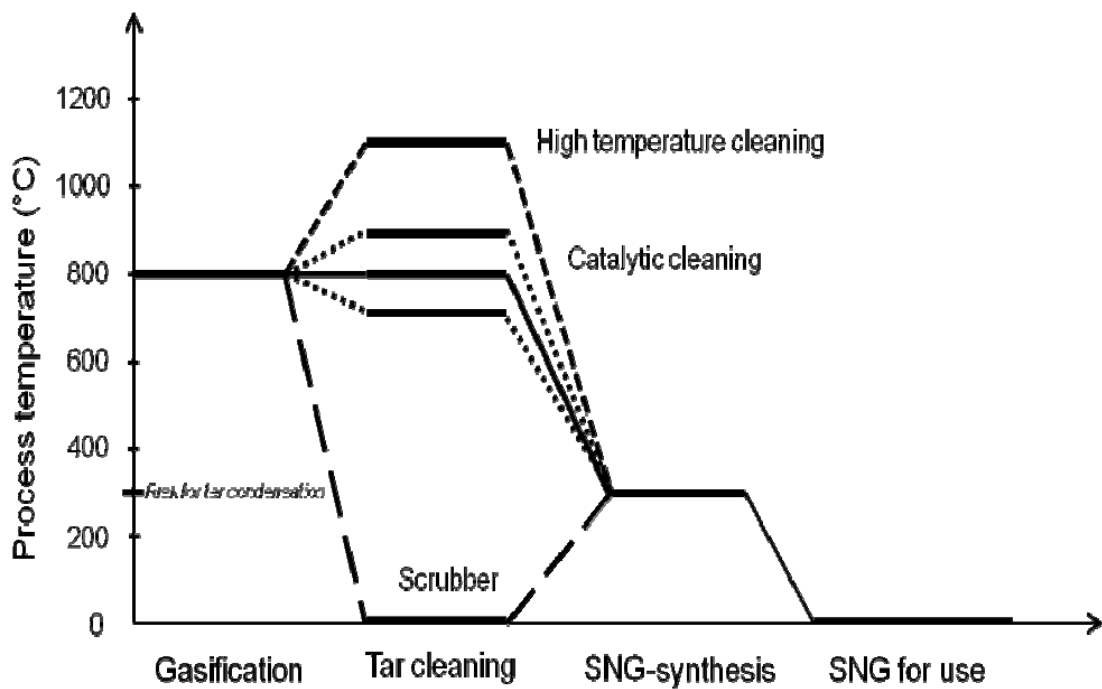

Figure 3 Heat losses from tar cleaning in SNG-production

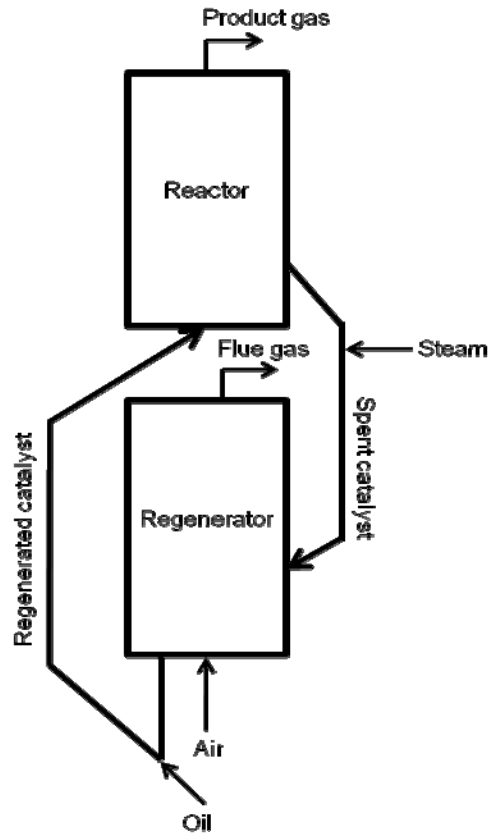
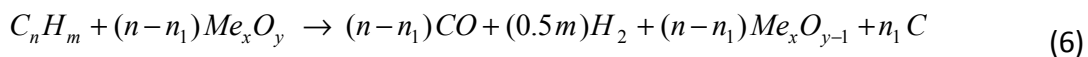

Figure 4 Schematic picture of an FCC-unit[15]

2.1 Tar cleaning by Chemical Looping Reforming

The tar cleaning method explored in this work is based on the CLR process, originally presented by Mattisson et al [16]. The reactor system is operated at atmospheric pressure and utilizes a circulating metal oxide as oxygen supplier and heat carrier for partial oxidation of the tar components into CO and H₂. In this manner, the product gas is not diluted by nitrogen as direct contact between the producer gas and the air is avoided.

The reactor system (CLR system) consists of two fluidized bed reactors, one for air (AR) and one for the tar containing producer gas called fuel reactor (FR), **Fig 5**. The FR in this work is designed as a bubbling fluidized bed to provide a good estimation of the gas/solid contact, but the concept could be applied to two circulating fluidized beds as well. Two loop seals (LS), fluidized with inert gas or steam, prevent gas cross-contamination of the effluents from respective reactor, but enable the catalyst to circulate between the two reactors. The metal oxide Me_xO_y is reduced to Me_xO_{y-1} during the partial oxidation of the tar components (C_nH_m) in the reformer according to



By reducing the Me_xO_y to Me_xO_{y-1} an endothermic reaction is usually generated. Besides the desired tar reforming reaction, additional carbon forming reactions cause carbon deposit on the MeO. Simultaneously, as the Me_xO_{y-1} is re-oxidized to Me_xO_y in a strongly exothermic [17] reaction in the AR, carbon deposits on the catalytic surfaces are oxidized to CO_2 according to

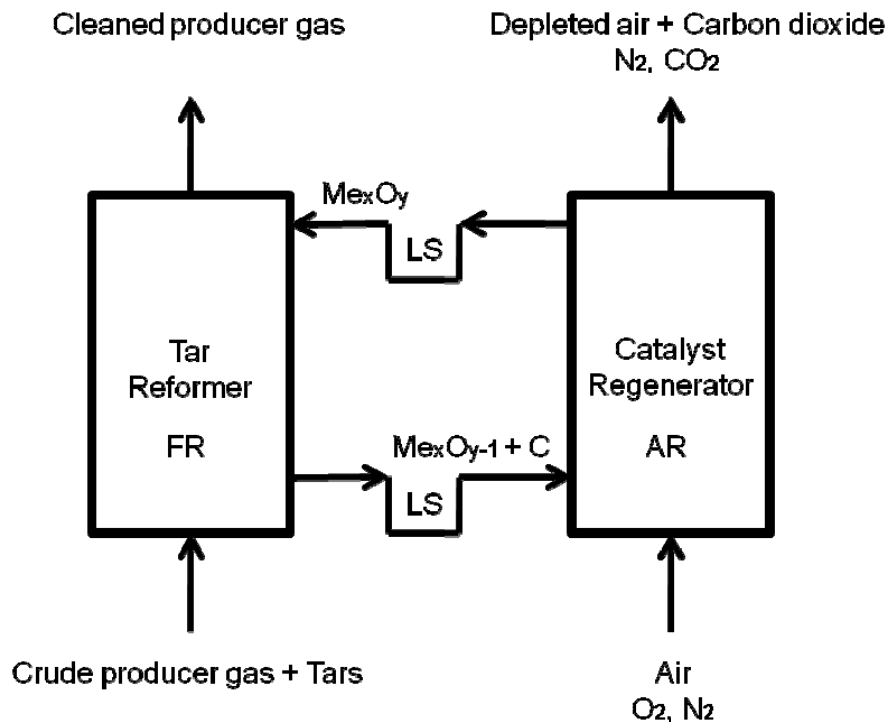
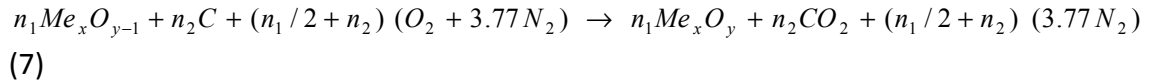

Figure 5 Tar cleaning by Chemical-Looping Reforming

2.2 Catalysts

Studies have shown that metal oxides, such as NiO [4, 9, 18], Fe_2O_3 [4, 6, 18], Mn_3O_4 [18, 19] and CuO [2, 18] supported on various inert materials are promising as oxygen-carriers and tar reforming catalysts. In this work, ilmenite (Fe_2TiO_3 in its most reduced form), a naturally occurring mineral with a bulk price comparable to hard coal, is investigated as tar reforming catalyst. So far, ilmenite has only been tested as a tar catalyst in one investigation [20]. However, it has been commonly used as oxygen-carrier for Chemical-Looping Combustion operations [20-22] (CLC). CLC operations have demonstrated that ilmenite particles are not fully oxidized in their crude state. The degree of oxidation increases with repeated cycles in the CLC [20]. During the

cyclic periods of oxidation and reduction, the porosity of the particles increases and so does the reactivity. The increasing reactivity can most likely be attributed to the enlarged surface area, as a result of the porous structure. A three-day CLC experiment carried out by Leion et al. showed that the area increased from 0.11 to 0.28 m²/g [20]. The conclusion drawn in that work was that ilmenite is an attractive oxygen carrier in CLC processes, with no decrease in reactivity towards pure methane or syngas (50% CO and 50% H₂). In addition to operating with gaseous fuel, Berguerand and Lyngfelt showed that the properties of ilmenite were sufficient to convert solid fuels in CLC [23].

One additional catalyst with manganese oxide as reforming agent is investigated in this work. The catalyst (M4MgZ1150) consists of 40% Manganese oxide (Mn₃O₄) supported on 60% Magnesium-Zirconium oxide (MgZrO₃) and was originally developed as an oxygen carrier for the CLC process [24]. Johansson et al. investigated the potential of the M4MgZ1150 as oxygen carrier for CLC operations and confirmed that the material was suitable as it could handle continuous redox reactions and in the same time showed high reactivity [25]. This implies that the material is suitable even for the CLR system where the catalyst is continuously exposed for reduction and oxidation reactions. Mendiara et al [26] investigated the tar reforming activity of the M4MgZ1150 in batch experiments with toluene as tar component at 600 and 800°C. They concluded that the material showed high reactivity towards the tar, reforming it at both temperatures.

3 - Methodology

This work is based upon experiments conducted in both a cold and a hot CLR system. The cold system is built in a transparent Perspex material and is identical sized to the hot system built in high temperature resistant steel. The idea of conducting tests in a cold system is the possibility to visually revise and understand the fluid dynamics, which cannot be done in the hot system, since, visual access is impossible. The fluid dynamics in a reactor system of bench-scale size is most likely influenced by wall effects, the cold and the hot systems were therefore identically sized. The methodology used in this study can basically be explained by two integrated blocks, **Fig 6**. The two blocks symbolize the investigations made in the cold system and hot system respectively. The integration between the systems is the transfer of fluid dynamics parameters that are investigated in the cold system.

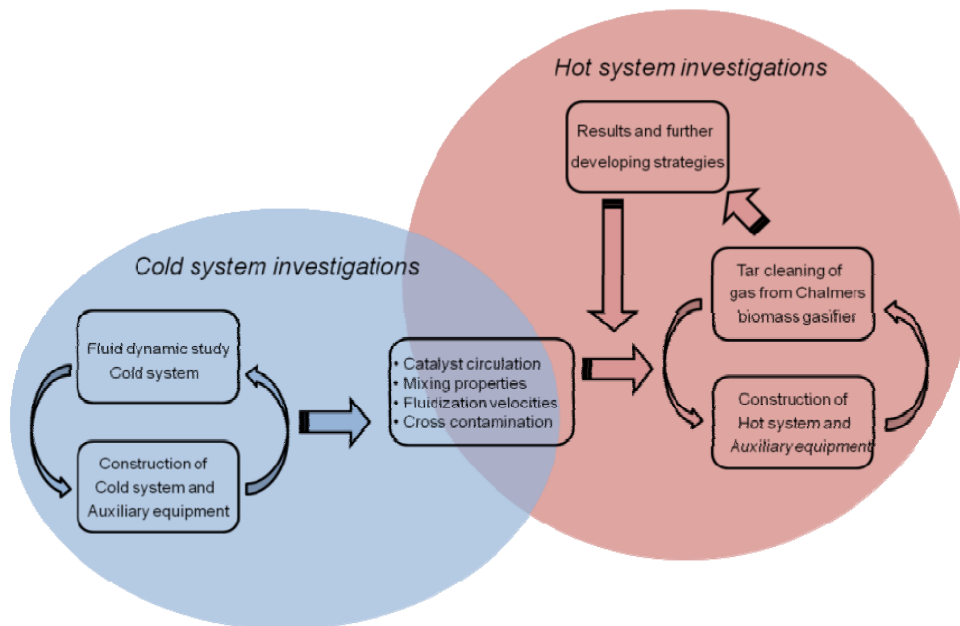

Figure 6 Schematic picture of the methodology structure used in this work

3.1 Cold System investigations

The simplified scaling relationships presented by Glicksman et al. can be used to enable transfer of fluidization data between a hot and a cold reactor system [27].

Glicksman et al showed by experiment that sufficient agreement in data between two systems can be achieved if a number of dimensionless numbers (8) is kept constant.

$$\frac{u_0^2}{gL}, \frac{\rho_s}{\rho_f}, \frac{u_0}{u_{mf}}, \frac{L_1}{L_2}, \frac{G_s}{\rho_s u_0}, \Phi, \text{ Particle size distribution} \quad (8)$$

The fluidization medium, particle density, etc. for the cold system was determined by comparing the dimensionless numbers for the hot and the cold systems. **Table 2** summarizes the operating parameters and these dimensionless numbers for the AR and FR in the hot and cold system. The gas density for air is four times lower in the hot system operated at 800°C in comparison to the cold system operated at 25°C. If air is used as fluidization medium in the cold system, then the particle density has to be increased by a factor four to fulfill the density ratio between the solids and fluid. The scale analysis was conducted with pure nickel (5240 kg/m³) as reference catalyst in the hot system. In this case, a bed material with a density of 21 000 kg/m³ would be needed. It was therefore selected to use Helium as fluidization medium and to scale the particle density. The combination of silica sand (2600 kg/m³) together with helium showed sufficient match in the dimensionless density ratio for the hot and the cold system, and was therefore chosen.

A drawing of the cold CLR system setup is shown in **Figure 7**. The cold system can be fluidized with air or helium. To minimize effects from static electricity between the particles and the Perspex surfaces, the gas is humidified in an air tight water bottle. Flow control valves are mounted on the outlets of the FR and AR for regulation of pressure in each reactor. In this manner, it is possible to recreate the difference in operating pressure between the FR and AR in the hot system. The fluidization gas to the FR, AR, Inferior LS (ILS) and Superior LS (SLS) is controlled by rotameters. The system can be monitored via 24 pressure taps with accompanying pressure transducers. The pressure can be measured as differential pressure between two taps in the system or as differential pressure between one tap and atmospheric pressure. A manually controlled valve is mounted in the downcomer for solid circulation rate measurements. The solid circulation is measured by closing the valve in the downcomer with simultaneous chronometer monitoring. Intermediate times are registered when the sand column reached 1, 2 and 3 cm of height in the downcomer. The registered heights (h_i') are recalculated to mass fluxes in downcomer ($G_{s,Downcomer}$) from the density of the bed material (ρ_{solid}) according to

$$G_{s,Downcomer} = \sum_{i=1}^n \frac{h_i'}{n} \cdot \rho_{solid} \quad [kg/m^2s] \quad (8)$$

Table 2 Operating parameters and dimensionless numbers for the hot and cold unit

Parameter	Units	Hot AR	Hot FR	Cold AR	Cold FR
Media	(gas)	Air	Raw gas	Helium/Air	Helium/Air
Temperature	T (K)	1173	1173	293	293
Pressure	P (Pa)	1×10^5	1×10^5	1×10^5	1×10^5
Gas viscosity	μ (Pa s)	4.59×10^{-5}	3.43×10^{-5}	1.96×10^{-5} / 1.82×10^{-5}	1.96×10^{-5} / 1.82×10^{-5}
Gas density	ρ_f (kg/m ³)	0.297	0.276	0.146 / 1.188	0.146 / 1.188
Bed geometry	(m)	L	L	L	L
Particle diameter	d_p (μ m)	150	150	150	150
Solids density	ρ_s (kg/m ³)	5240	5240	2600	2600
Superficial velocity	u_o (m/s)	1.00	0.039	1.00	0.039
Sphericity	Φ	0.9	0.9	0.84	0.84
Particle size distribution	ρ	P	p	p	p
Solid flux	G_s (kg/m ² s)	G_s	G_s	$0.5 \times G_s$	$0.5 \times G_s$
Dimensionless number	ρ_s / ρ_f ($\times 10^4$)	1.76	1.89	1.58 / 0.218	1.58 / 0.218
Dimensionless number	u_o / u_{mf}	40.82	1.12	40.32/37.45	1.57 / 1.46

Table 3 Geometrical measures of the CLR-system

Reactor part	Cross-sectional (mm)	Height (mm)
Fuel reactor (FR)	50 x 50	380
Air reactor (AR)	20 x 20	460
Superior loop seal (SLS)	23 x 23	120
Inferior loop seal (ILS)	23 x 23	50

The cold system investigations are conducted to create understanding of the fluid dynamics in the CLR system. The experimental work also contributes with skills and experience in how to run the system on physical ground. Parameters that are considered to have high influence for creating stable operation in the CLR are investigated in this work. These investigated parameters are:

- The potential of controlling catalyst circulation during fluidization with helium or air
- Possibilities to transfer governed data and robust operating conditions to the hot system
- Cross-contamination of the effluents from respective reactor, i.e. gas leakage

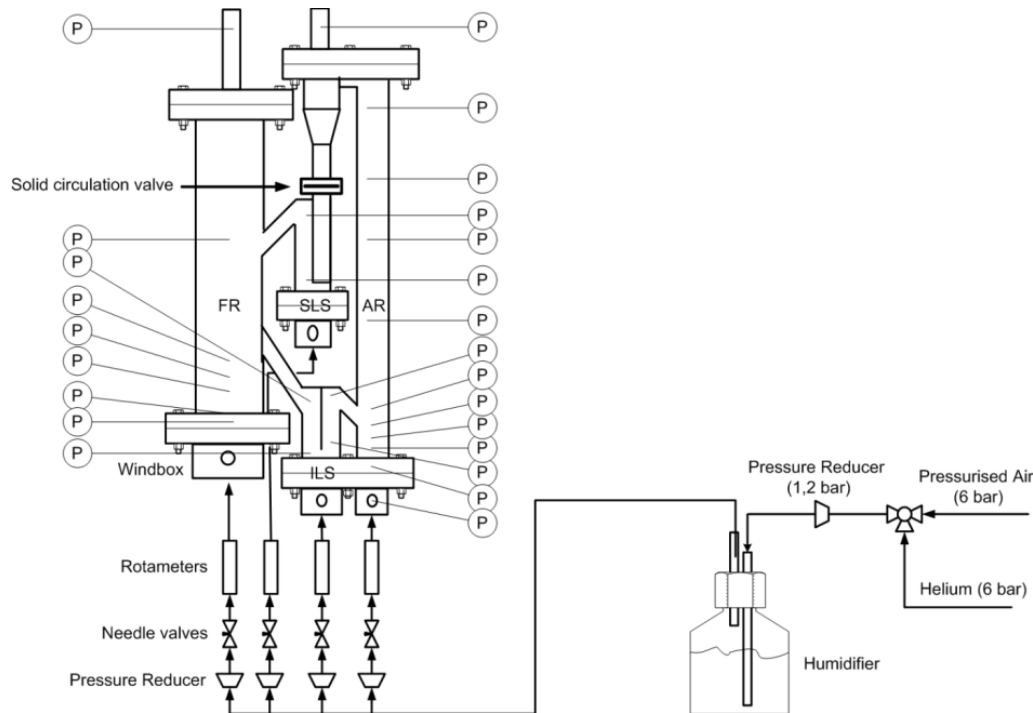

Figure 7 Cold system setup

3.2 Hot System investigations

The hot reactor with auxiliary system was built in the vicinity of the Chalmers gasifier and after almost two years of work the CLR system was operational. The CLR reactor within this project is developed for research and each part of the reactor can be monitored by means of temperature and pressure, **Fig 8**. The geometrical measures of the reactor system are shown in **table 3**. Catalyst samples can be collected via the secondary cyclone during operation in the CLR, which is implemented downstream of the AR (1). The particles from the secondary cyclone are transferred to the FR or to a sampling bottle by stepwise opening and closing of two control valves (2). The tar reforming reactions and regeneration reactions, can with regard to temperature, be optimized separately from each other with a temperature difference of 200°C. This is achieved by separate heating of the two oven halves (3), together with an air-cooled jacket on the FR (4). Two separate mass flow regulators (5), one for air and one for nitrogen is used for controlling the oxygen concentration in the inlet feed to the AR. The oxygen concentration can be varied from 0 to 21 mole%. Helium is used to fluidize the SLS and ILS and the flows are controlled by two separate mass flow regulators (6). After the AR, the gas is cooled and dried in a gas conditioning system (7). The content of CO, CO₂ and O₂ in the gas out of the AR is analyzed online by Non Dispersive Infrared analyzers (NDIR) for CO and CO₂, respectively paramagnetic analyzer for O₂ (8). It is also possible to analyze the AR effluents by a micro gas chromatograph, micro-GC (Varian 4900). The GC is used to determine the amount of helium in the AR, which originates from the feed to the two LS (9).

The raw gas pipe between the FR and the gasifier (10), as well as the pipe connection between the FR and the gas conditioning system (11), is heated to 400 °C to preclude tar condensation. The concentration of tars in the reformed gas is measured by Solid Phase Adsorption [28] (SPA) in the heated pipe between the FR and the gas conditioning system (12). The collected samples are sent for analysis in a Gas Chromatography followed by a Flame Ionization Detector (GC-FID). The reformed gas leaving the FR is cooled (13) and the moisture content in the reformed gas is measured by weighing the condensate (14). The dry reformed gas is further analyzed by a micro-GC (9). The tar concentration and the dry gas composition in the raw gas are measured by SPA followed by GC-FID and micro-GC respectively, in a separate system for monitoring the gasifier. A detailed description of the hot CLR system with accompanying analysis equipment can be found in paper I.

The proposed tar cleaning method is investigated by using ilmenite as catalyst and raw gas (containing roughly $30 \text{ g}_{\text{tar}}/\text{m}^3_{\text{gas}}$) from Chalmers biomass gasifier (Paper II). Further investigation was performed by using a manganese catalyst (Paper III). The fundamental criteria to assess the performance of the tar cleaning method are as follow:

- The possibilities of obtaining continuous transport of catalysts and oxygen from the regenerator to the reformer
- The possibilities of reforming tars in the reactor system by using a natural ore like ilmenite or a manufactured catalyst like the M4MgZ1150
- Investigating how changes in oxygen concentration and temperature affects tar reforming and gas composition in the FR
- Investigating the possibility of maintaining high activity of the catalyst by continuous oxidation of the formed carbon in the regenerator reactor
- Investigating the possibility for catalytic conditioning of the gas and optimization for SNG production

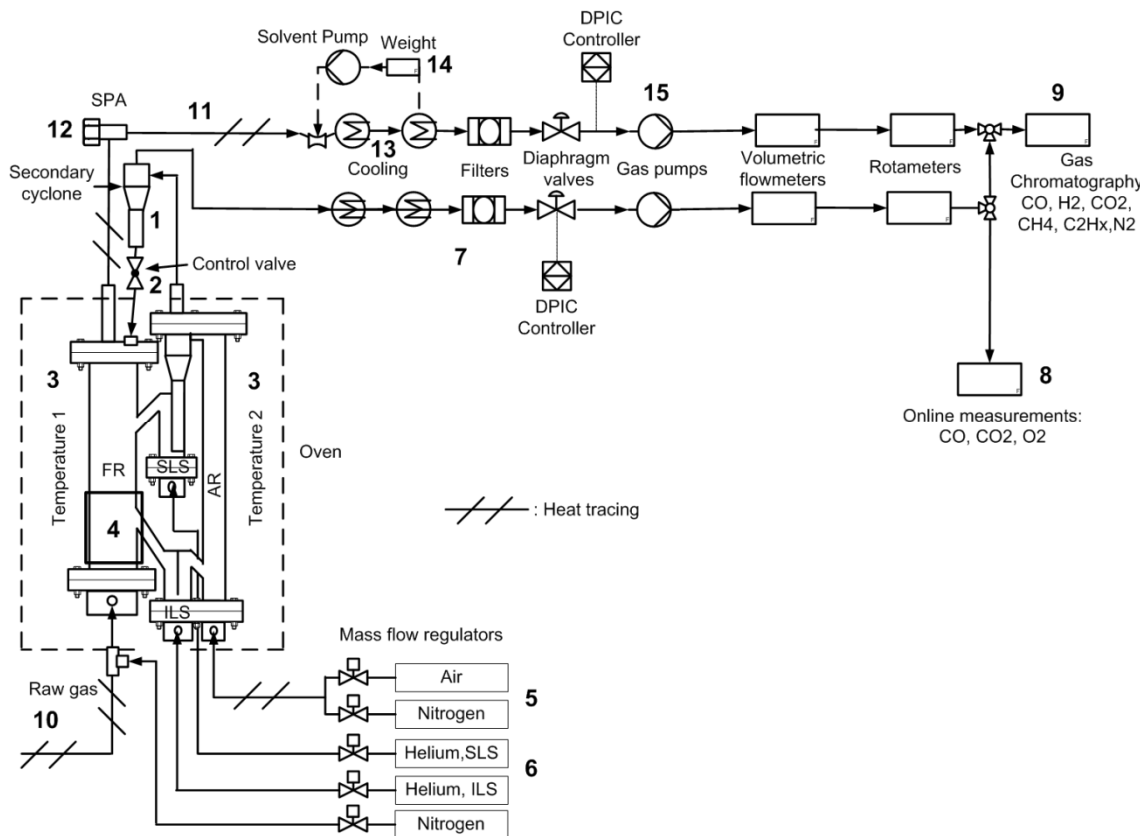

Figure 8 Drawing of the hot CLR setup

3.3 Development of online water measurement

The raw gas flow in the FR is controlled by a gas pump (15), **Fig 8**, operating on the dry reformed gas. This means that one has to consider water consumption and volume increasing reactions in the FR, e.g. the water-gas shift reaction. To obtain constant gas flow between two experiments, an iterative procedure is necessary. The activity of a catalyst can change during operation. For example, ilmenite increases its activity with cyclical periods of oxidation and reduction. This means that the method for monitoring moisture content in the reformed gas by weighting the condensed water, becomes too slow and inadequate for the application. To tackle this problem, a method that uses relative humidity (RH) to determine moisture content was developed. Using a RH-sensor, the moisture fraction of the gases is determined from the saturation pressure, P_{sat} , according to

$$X_{vol,m} = \phi \frac{P_{sat}}{P} \quad (10)$$

$$P_{sat} = \exp(23.82 - 4193/(T - 32)) \quad (9)$$

where $X_{vol,m}$ is the volumetric fraction, ϕ is the RH, P is the total pressure in the gas (Eq. 9 is an integration of the Clausius-Clapeyron equation under the assumption that the evaporation enthalpy is independent of temperature). Additionally, the temperature needs to be measured to find the saturation pressure. A prototype that utilizes the method for RH was built and investigated in a transversal study for measuring moisture content in flue gases from biomass fired boilers. The drawing of the prototype is shown in **Figure 9**. The flue gas is extracted from the flue gas duct (1), separated from particles by a filter (2) and cooled to the targeted temperature in a tube that passes through a temperature controlled oil bath (3). The RH, the temperature and the pressure are measured in a cell (4). A manometer is used for the pressure and a PT100 resistance detector for temperature detection, while the RH is determined from the sensitivity in electrical conductivity of a polymer to the surrounding gas moisture-content.

The dynamic behavior of the method was investigated in the Chalmers 12 MW_{th} research CFB-boiler:

- measurement of relative humidity and temperature in extracted flue-gas
- measurement of moisture content by Fourier Transform Infrared Spectroscopy FT-IR analyzer in (the same) extracted flue-gas
- water injection to the fuel feed (inducing step function)

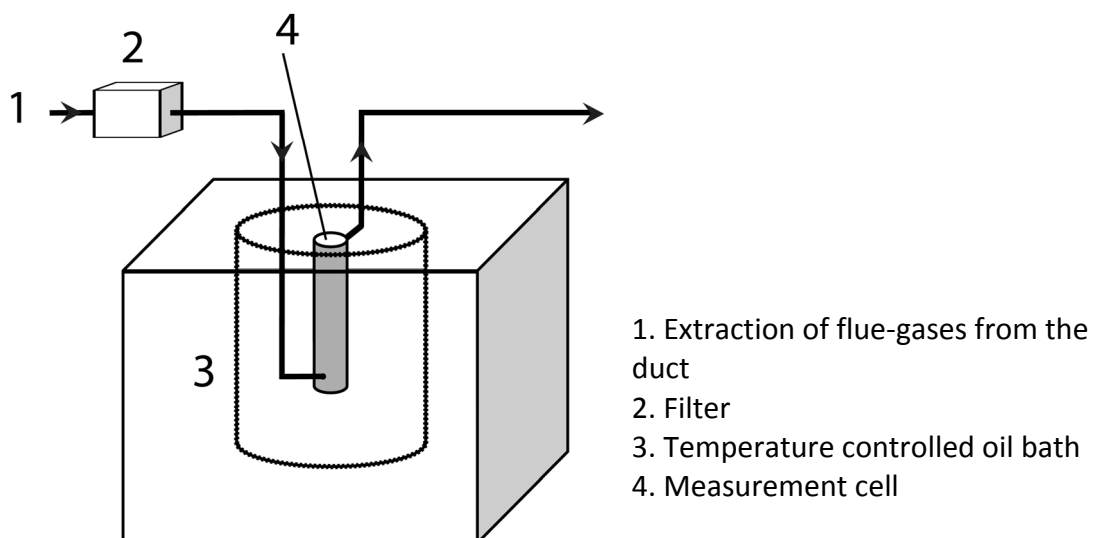

Figure 9 Measurement advice for moisture content

4 - Results and discussion

4.1 Cold system

A fluid dynamics investigation of the cold CLR system was carried out to find robust operating conditions to be applied in the hot CLR system. One of the investigated parameters was the control of solid circulation rate, which is a fundamental requirement in the proposed tar cleaning method for transport of oxygen and to recover catalytic surfaces. In **Figure 10**, solid circulation flux is plotted against the superficial velocity in the riser. The figure shows that, independent, of gas efficient control of solid circulation between the two reactors can be achieved by varying the fluidization velocity in the riser. The two distinct plateaus in the air experiments indicate that it is possible to control the solid inventory in the FR by using the ILS as solid flow valve. The throttling effect can be explained by wall friction induced by the small volume in the ILS and is in accordance with previous observation by Pröll et al [29].

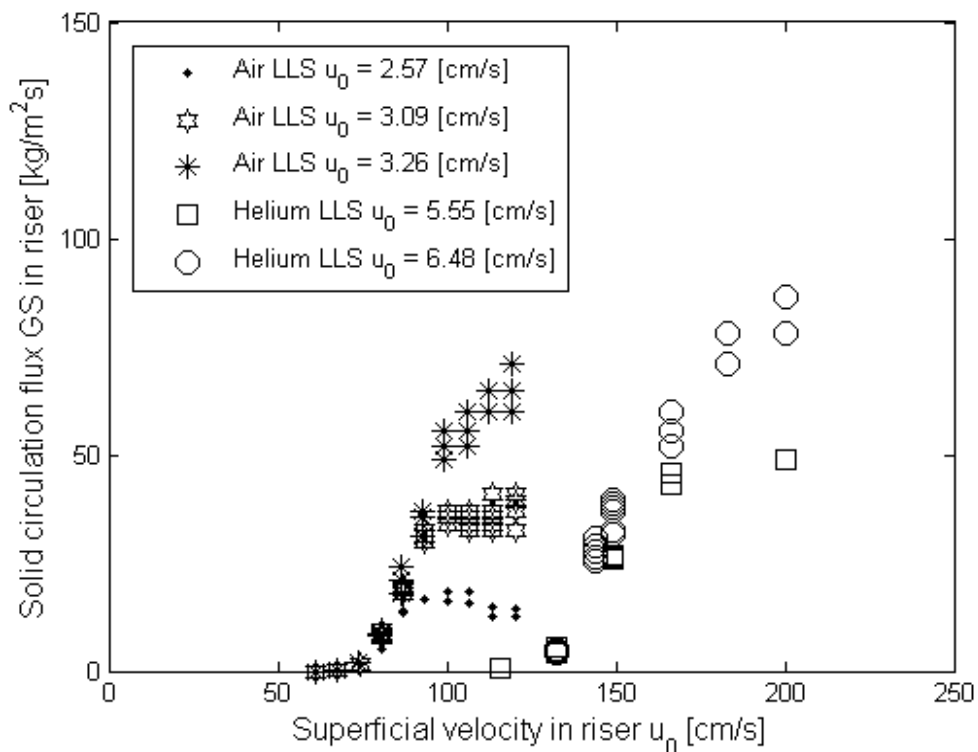

Figure 10 Solid circulation fluxes versus superficial gas velocity in riser

The cross-contamination of the effluents from respective reactor was investigated in the cold CLR. The oxygen concentration was measured in the effluents from the FR, as the FR SLS and ILS were fluidized with nitrogen and the AR was fluidized with air. Oxygen concentration in the AR and pressure difference between the AR and FR are plotted against superficial velocity in the riser in **Fig 11**. The figure shows that the oxygen concentration in the FR is less than 0.4 mole% at the highest fluidization velocity in the riser, which indicates that the performance of the loop-seals is sufficient. Nevertheless, a trend in oxygen concentration can be noted the oxygen concentration in the FR is increasing with increased superficial velocity in the AR. The reason for the higher oxygen concentration is associated with the increased pressure difference between the AR and FR, caused by the raised gas flow in the riser.

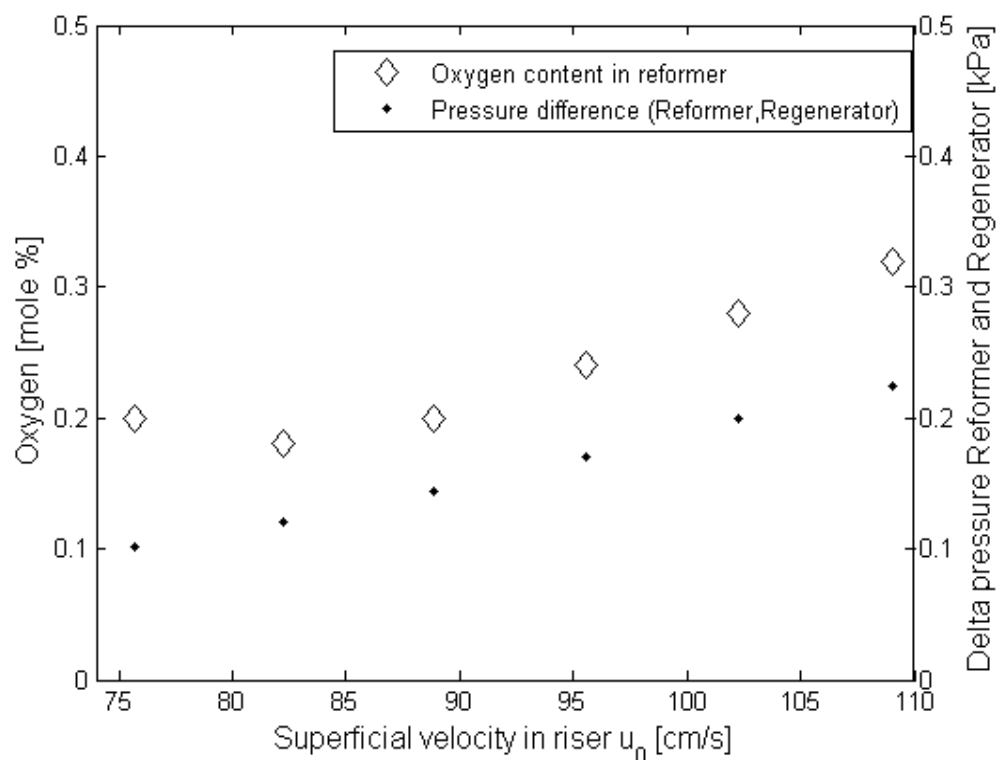

Figure 11 Oxygen leakage and pressure difference between AR and FR versus superficial velocity in riser

Sufficient agreement in the dimensionless numbers for the scaling relationship is important, if data from the cold system experiments is to be transferred to the hot system. The comparison of dimensionless numbers between the hot and the cold system, **table2**, shows that the solid/gas density ratio when operated with helium is well adjusted, with deviations of 11% in the AR and 20% in the FR, whereas the same dimensionless numbers with air differs with a factor of 8 in the AR and a factor 9 in the FR. The ratio for superficial velocity and minimum fluidization velocity deviates with 1% for the AR and 40% for the FR between the hot unit and the cold unit fluidized with helium. On the other hand, the ratio for superficial velocity and minimum fluidization

velocity deviates with 9% for the AR and 30% for the FR between the hot unit and the cold unit fluidized with air. The deviation in the ratio between superficial velocity and minimum fluidization velocity for the FR is of less importance in the CLR compared to the same ratio for the AR. The reason to this is that the solid flux, controlled by the fluidization properties in the riser, is more crucial for the operation.

4.2 Hot system

Two experiments were carried out in the CLR to guarantee that no catalytic effects were observed from the reactor material or the silica sand. Dry gas composition from one of the experiments, performed at an operation temperature of 800°C, is shown in **Fig 12**. The middle bar represents the gas composition downstream the CLR and the other bars represent the raw gas composition before and after the operation of the CLR. As shown in **Fig 12**, the CLR reactor operated with silica sand has a negligible effect on the gas composition. Furthermore, the SPA analysis of the case also confirmed that the tar content or composition was unaffected by the CLR system. This suggests that no catalytic effects are produced by either the reactor material or by the silica sand.

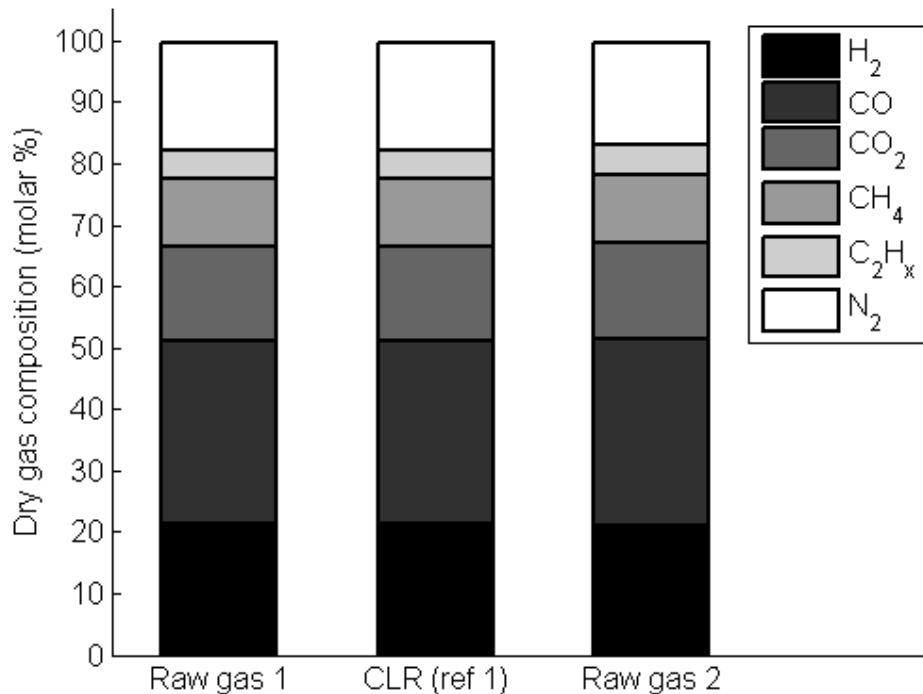

Figure 12 CLR reference experiments with silica sand

Table 4 Tar composition in raw gas (Reference) and reformed gas leaving the CLR for 60 wt-% ilmenite in silica sand and for 23 wt-% manganese catalysts in silica sand

Catalyst	Ilmenite		Manganese	
	Reference	Reformed	Reference	Reformed
Measure position				
Mole% O ₂ in AR	-----	1,0	-----	2,2
Phenol	0,98	0,01	2,18	0,07
o-Cresol	0,03	0,00	0,26	0,00
m-Cresol	0,15	0,00	0,48	0,00
p-Cresol	0,04	0,00	0,15	0,00
Benzene	0,65	1,90	0,51	1,18
Toluene	0,71	0,17	0,66	0,60
m/p-Xylene	0,14	0,00	0,19	0,07
o-Xylene	1,06	0,16	1,10	0,85
Indan	0,05	0,17	0,06	0,16
Indene	2,94	0,05	3,76	0,61
Naphthalene	7,53	10,77	7,54	8,41
2-Methylnaphthalene	1,10	0,06	1,32	0,37
1-Methylnaphthalene	0,70	0,03	0,83	0,17
Biphenyl	0,47	0,84	0,54	0,65
Acenaphthylene	2,03	0,37	2,40	1,24
Acenaphthene	0,13	0,01	0,18	0,04
Fluorene	0,65	0,09	0,86	0,09
Phenanthrene	1,66	1,45	1,77	1,50
Anthracene	0,29	0,18	0,53	0,33
Fluorantene	0,41	0,45	0,53	0,36
Pyrene	0,46	0,42	0,60	0,36
Unknowns	5,54	0,92	6,43	1,21
Total tar	27,70	18,04	32,89	18,27
Tar conversion	-----	35,0	-----	44,5

The tar cleaning concept and the tar reforming activity of ilmenite and manganese are evaluated by comparing the tar content of the gas in and out of the FR. **Table 4** summarizes the 21 analyzed tar components from the SPA-samples in the raw gas as well as in the reformed gas leaving the CLR. In this case, the tar data is selected from the runs with the highest tar reduction. The table is organized in accordance to: the two investigated catalysts (ilmenite or manganese), the position for tar measuring (reference gas or reformed gas) and the oxygen concentration in the air reactor (mole% O₂ in AR).

The highest degree of tar reduction (44.5%) was achieved with 23 wt-% manganese catalyst in silica sand at a CLR-operation temperature of 800°C. The case with 60 wt-% ilmenite in silica sand showed a tar reduction of 35% at 800°C.

The analysis of the SPA samples gives, in addition to the total tar, also information on different tar molecules. This information reveals how tar structures change during CLR operation. **Figure 13** and **14** show the overall changes in tar composition between the raw gas and the reformed gas for ilmenite and for manganese experiments. In **Figure 13**, the tar concentrations are shown for the case with 60 wt-% ilmenite in silica sand at the temperature of 800°C and 1% O₂ in the AR. In **Figure 14**, the tar concentrations are shown for the case with 23 wt-% manganese catalysts in silica sand at 0.6, 1 and 2.2% oxygen in the AR at the temperature of 800°C. Here, the tar components have been divided into the 7 groups: Phenols, Benzene, 1-ring aromatic compounds with branches (1-ring branched), naphthalene, 2-ring aromatic compounds with branches (2-ring branched), 3 to 4 ring aromatic compounds without branches (3 and 4-rings), and finally “unknowns”. The reason to group the tar components this way is to display patterns for the tar decomposition. A general trend seen in both **Fig 13** and **14** is that the benzene and naphthalene fractions are increased. This can be explained by reforming reactions, which takes place by stripping the side group off from phenols and branched tar molecules forming pure aromatics. A general trend for the manganese case, **Fig 14**, is that increased oxygen concentration increases the conversion of phenols, 1 to 2-ring branched aromatic compounds and unknowns. In other words, the tar decomposing reactions benefits from increased oxygen transfer from the AR to the FR.

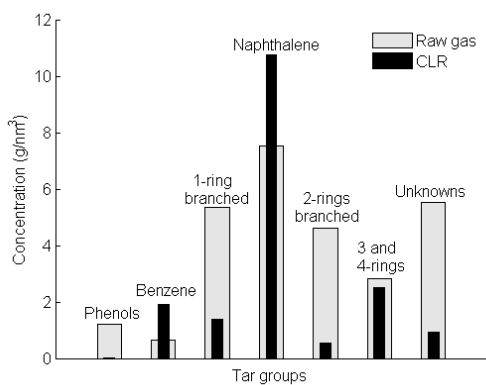

Figure 13 Tar group compositions for raw gas and reformed gas (Ilmenite)

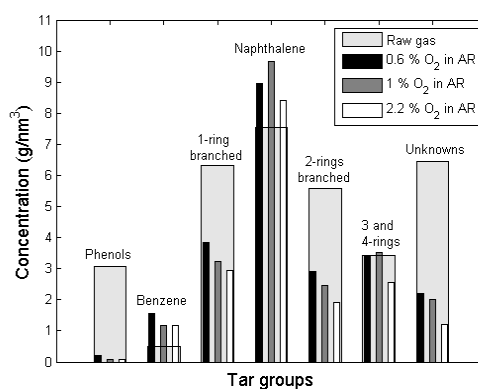

Figure 14 Tar group composition for raw gas and reformed gas (Manganese)

The dry composition of the raw gas is compared with the reformed gas after the CLR-system to investigate if the ilmenite and manganese catalysts show any catalytic effect on the permanent gases. In **Fig 15**, the gas compositions from the manganese experiments at 800°C are shown for the raw gas and the reformed gas at the oxygen concentrations of 0.6, 1 and 2.2 mole% in the inlet feed to the AR. A general trend for all the investigated oxygen concentrations is that the H₂ and CO₂ concentrations increase, while the CO concentration decreases. Furthermore, the concentrations of CH₄ and acetylene decrease slightly. The increase in H₂ can to a large extent be

explained by increased water-gas shift activity (WGS) and the ratio between H₂/CO is shifted from approximately 0.6 in the raw gas to 1 in the reformed gas. **Figure 16** shows the dry gas composition from the ilmenite experiments at 800°C for the raw gas (left bar) and the dry reformed gas (right bar) downstream of the CLR. The nitrogen content in the outlet stream of the FR is 21% lower than the fed raw gas. Since, the same amount of nitrogen is fed to the FR, the reduced nitrogen concentration is linked with an overall volume increase of permanent gases. The difference in concentration between the reformed gas and the raw gas is presented in **Fig 17**, in which the raw gas and the reformed gas are normalized with regards to their respective nitrogen contents. The increase in H₂ and CO₂ together with the decrease in CO, **Fig 17**, can to a large extent be explained by increased water-gas shift activity induced by the ilmenite. The H₂/CO-ratio, when comparing the raw gas to the reformed gas leaving the CLR system in **Fig 16**, shifts from approximately 0.7 to 3.

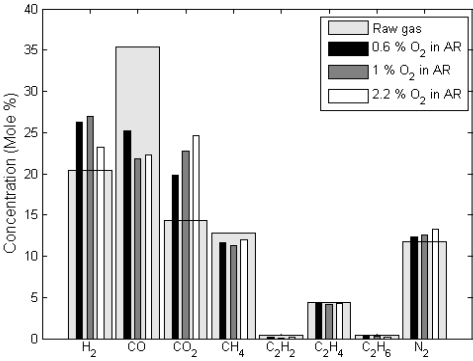

Figure 15 Dry gas compositions for raw gas and reformed gas (manganese)

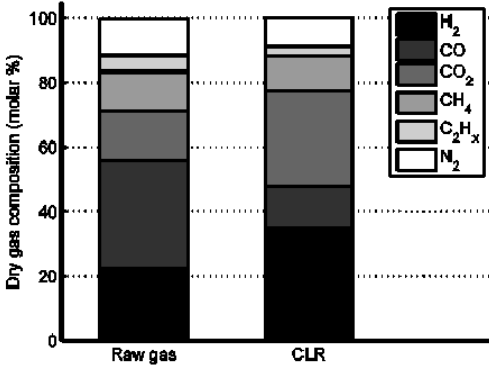

Figure 16 Dry gas compositions for raw gas and reformed gas (Ilmenite)

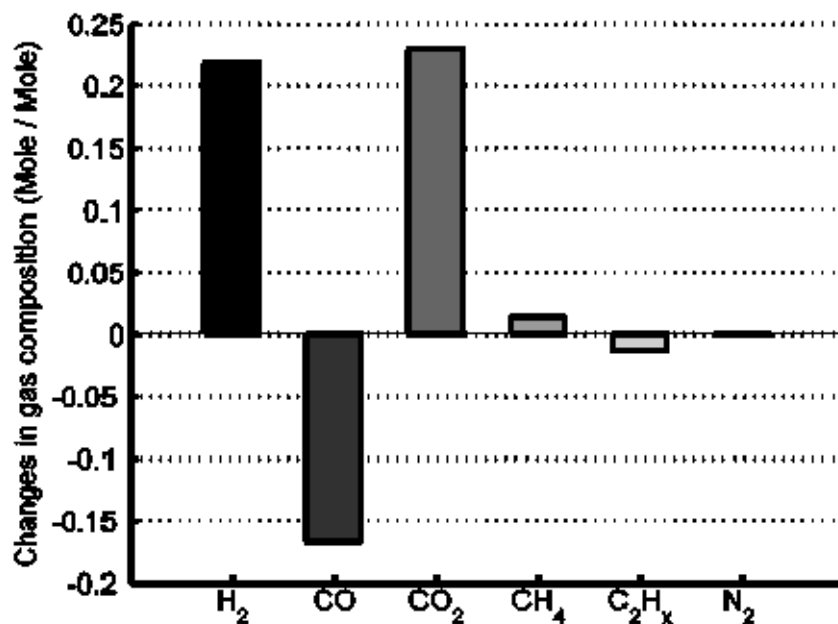

Figure 17 Changes in gas compositions between raw gas and reformed gas (ilmenite) During CLR operation, the concentration of carbonaceous gases leaving the AR as well as the total gaseous carbon fed to the FR are monitored. Integrating values under steady-state condition gives an indication of the proportion of carbon deposit actually regenerated in the AR. Experiment was performed at 700 and 800°C using both catalyst materials. **Figure 18** shows the results.

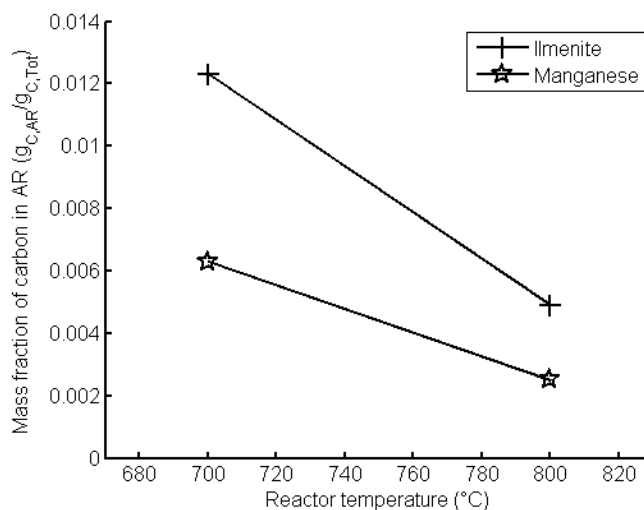

Figure 18 Ratio of regenerated carbon deposit in the AR ($g_{C,AR}$) to the total carbon fed in the CLR ($g_{C,tot}$) as a function of temperature

They indicate that regeneration of the carbon deposit on the catalyst does occur in the AR, see **Fig 18**. Note that as much as 1.2% of total carbon in the raw gas flow

leaves the CLR via AR in the case of ilmenite at 700°C. Moreover, as higher temperature benefits the gasification reactions in the FR, less carbon is susceptible to follow the catalyst and burn in the AR. This aspect is distinct in **Fig 18**; for both catalysts.

4.3 Development of online water measurement

The dynamic behavior of the calibrated method for water measurements was investigated in the Chalmers research CFB boiler, producing a step function of moisture in the flue gases by adding water to the fuel feed. The results, presented in **Fig 19**, reveal that the RH-sensor signal responds to frequencies within seconds, while the FT-IR analyzer detects the change in moisture approximately two minutes later. However, the used FT-IR analyzer filters the measurement signal retroactively on a minute basis; when treating the RH signal with the same filter, they become comparable. The filtered signal from the RH-measurement and the FT-IR measurement show no sign of hysteresis in the RH-measurement, meaning that the signals respond equally to both positive and negative changes in moisture content. Finally, using the method for detection of fluctuations yields a moisture content is in the same order as the sampling time of the instrument (5 seconds).

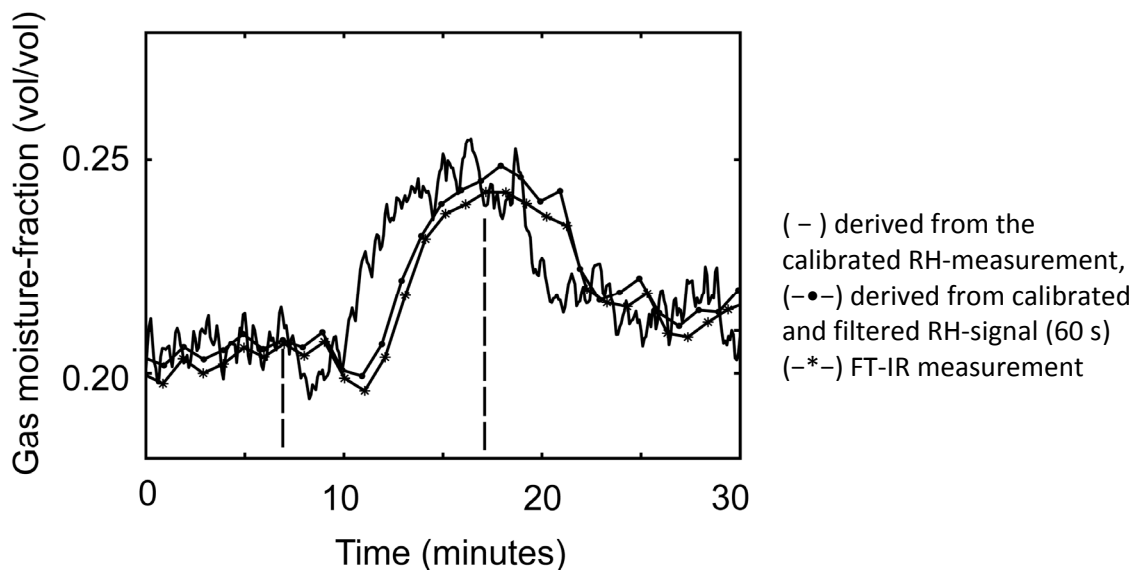

Figure 19 Moisture fraction of the flue gas during the dynamic test in Chalmers CFB-boiler.

5 - Conclusions

The feature in this work has been to investigate secondary catalytic tar cleaning of raw gas, produced from gasification of biomass. A novel method that combines tar cleaning with catalyst regeneration by Chemical Looping Reforming (CLR) has been investigated. The tar cleaning method was evaluated by conducting experiments in two identically sized dual fluidized bed reactor systems: a cold system in transparent Perspex material and a system made of high temperature resisting steel.

The possibilities to control the circulation rate of the catalyst in the reactor systems were investigated in a fluid dynamic study of the cold system (Paper I). The performed experiments (with both air and helium) points out that, independently of fluidization gas, solid circulation rate can be efficiently controlled by the fluidization velocity in the riser. However, the throttling effect which was seen during air fluidization in the ILS was not seen in the hot system. The ILS could therefore not be used as a valve for controlling the solid circulation in the hot system. This was also indicated already in the helium experiments. The comparison in dimensionless numbers (scaling laws by Glicksman et al) between Helium and the gases in the hot system showed good agreement. This implies that fluid dynamic patterns in the cold system are possible to transfer to the hot system. Performed leakage experiment pointed out that sufficient gas tightness in the loop-seals and for such related application is achieved.

Experiments in the hot system were conducted with raw gas from the Chalmers biomass gasifier, which contained roughly $30 \text{ g}_{\text{tar}}/\text{Nm}^3_{\text{gas}}$. The tar cleaning method was first demonstrated by using ilmenite (Fe_2TiO_3) as a catalyst (Paper II) and later on even with a manganese catalyst (Mn_3O_4 supported on MgZrO_3 , Paper III). Both experiments showed that the ilmenite and the manganese catalyst were continuously regenerated from carbon deposits. The total tar content was reduced by as much as 35% in the ilmenite case and 44.5% in the manganese case and no catalytic effects were observed from the reactor material itself. A general trend for both investigations was that the branched tars and phenols were to a large extent converted to pure aromatic compounds, while more activation energy was required to open the stable ring structure, i.e. benzene and naphthalene. Both catalysts showed water-gas shift activity: the H_2/CO ratio rose from approximately 0.7 in the raw gas to 3 downstream

of the reactor system for the ilmenite case and from 0.6 to 1 in the manganese case. The content of light hydrocarbons and methane were more or less not affected by any of the catalysts.

Finally, a new cost effective method for determine moisture content in a gas stream within rapid response time has been developed and experimentally validated. The idea is to enable online measurements for water content in the reformed gas exhausting from the CLR reactor. Here, the validation was, however, made on flue gas from a CFB-boiler, but the method can equally be used downstream of the tar cleaning reactor. Compared to the simplicity of the method, it showed relatively sufficient accuracy (<4% error). The results of the experiments show that the method is able to detect variations in moisture content within the order of seconds, without any significant hysteresis.

Future work

The results that have been presented in this thesis are based on the first experiences in the CLR system for tar cleaning. Additional, not yet evaluated experiments have been performed this year (2011). The analysis of these results will be used to further develop and optimize the reactor system.

6 - Notations

$g_{\text{tar}}/\text{Nm}^3_{\text{gas}}$: Mass of tars per normal cubic meter of product gas

CLC: Chemical Looping Combustion

CLR: Chemical Looping Reforming

CLS: Chemical Looping Systems

AR: Air Reactor

FR: Fuel Reactor

LS: Loop-Seal

SLS: Superior Loop Seal

ILS: Inferior Loop Seal

FCC: Fluid Catalytic Cracking

SPA: Solid Phase Adsorption

MeO: Metal oxide

Me_xO_y : Oxidized metal-oxide

$\text{Me}_x\text{O}_{y-1}$: Reduced metal-oxide

Micro-GC: Micro Gas Chromatography

RH: Relative Humidity

FTIR: Fourier Transform Infrared Spectroscopy

7 - References

1. Pfeifer, C. and H. Hofbauer, *Development of catalytic tar decomposition downstream from a dual fluidized bed biomass steam gasifier*. Powder Technology, 2008. **180**(1-2): p. 9-16.
2. Devi, L., K.J. Ptasinski, and F.J.J.G. Janssen, *A review of the primary measures for tar elimination in biomass gasification processes*. Biomass and Bioenergy, 2003. **24**(2): p. 125-140.
3. Li, C.S. and K. Suzuki, *Tar property, analysis, reforming mechanism and model for biomass gasification-An overview*. Renewable & Sustainable Energy Reviews, 2009. **13**(3): p. 594-604.
4. Dayton, D., *A Review of the Literature on Catalytic Biomass Tar Destruction*. 2002, NREL.
5. Taralas, G., M.G. Kontominas, and X. Kakatsios, *Modeling the thermal destruction of toluene (C₇H₈) as tar-related species for fuel gas cleanup*. Energy & Fuels, 2003. **17**(2): p. 329-337.
6. Uddin, M.A., et al., *Catalytic decomposition of biomass tars with iron oxide catalysts*. Fuel, 2008. **87**(4-5): p. 451-459.
7. Patrick C.A Bergman, S.V.B.v.P., Harold Boerrigter, *The Novel "OLGA" technology for complete tar removal from biomass producer gas*, in *Pyrolysis and Gasification of Biomass and Waste, Expert meeting, 30 2002*: Strasbourg, France.
8. Bangala, D.N., et al., *Catalytic gas conditioning: Application to biomass and waste gasification*, in *Industrial & Engineering Chemistry Research*. 1997. p. 4184-4192.
9. Caballero, M.A., et al., *Biomass gasification with air in fluidized bed. Hot gas cleanup with selected commercial and full-size nickel-based catalysts*. Industrial & Engineering Chemistry Research, 2000. **39**(5): p. 1143-1154.
10. Delgado, J., M.P. Aznar, and J. Corella, *Biomass Gasification with Steam in Fluidized Bed: Effectiveness of CaO, MgO, and CaO-MgO for Hot Raw Gas Cleaning*. Industrial & Engineering Chemistry Research, 1997. **36**(5): p. 1535-1543.

11. Rapagnà, S., et al., *Steam-gasification of biomass in a fluidised-bed of olivine particles*. Biomass and Bioenergy, 2000. **19**(3): p. 187-197.
12. Seemann, M.C., et al., *The regenerative effect of catalyst fluidization under methanation conditions*. Applied Catalysis A: General, 2006. **313**(1): p. 14-21.
13. Baker, E.G., L.K. Mudge, and M.D. Brown, *STEAM GASIFICATION OF BIOMASS WITH NICKEL SECONDARY CATALYSTS*. Industrial & Engineering Chemistry Research, 1987. **26**(7): p. 1335-1339.
14. Miyazawa, T., et al., *Catalytic performance of supported Ni catalysts in partial oxidation and steam reforming of tar derived from the pyrolysis of wood biomass*. Catalysis Today, 2006. **115**(1-4): p. 254-262.
15. Kunii, D. and O. Levenspiel, eds. *Fluidisation Engineering Second Edition*. ed. H. Brenner. 1991, Butterworth-Heinemann. 36-38.
16. Mattisson T, a.L.A. *Applications of chemical-looping combustion with capture of CO₂*. in *Second Nordic Minisymposium on Carbon Dioxide Capture and Storage, Göteborg, Sweden*. 2001.
17. Ryden, M., A. Lyngfelt, and T. Mattisson, *Synthesis gas generation by chemical-looping reforming in a continuously operating laboratory reactor*. Fuel, 2006. **85**(12-13): p. 1631-1641.
18. Rydén, M., et al., *Waste products from the steel industry with NiO as additive as oxygen carrier for chemical-looping combustion*. International Journal of Greenhouse Gas Control, 2009. **3**(6): p. 693-703.
19. Rydén, M., et al., *Ilmenite with addition of NiO as oxygen carrier for chemical-looping combustion*. Fuel. **In Press, Corrected Proof**.
20. Leion, H., et al., *The use of ilmenite as an oxygen carrier in chemical-looping combustion*. Chemical Engineering Research & Design, 2008. **86**(9A): p. 1017-1026.
21. Berguerand, N. and A. Lyngfelt, *Batch testing of solid fuels with ilmenite in a 10 kWth chemical-looping combustor*. Fuel, 2010. **89**(8): p. 1749-1762.
22. Leion, H., T. Mattisson, and A. Lyngfelt, *Solid fuels in chemical-looping combustion*. International Journal of Greenhouse Gas Control, 2008. **2**(2): p. 180-193.
23. Berguerand, N. and A. Lyngfelt, *Batch testing of solid fuels with ilmenite in a 10 kWth chemical-looping combustor*. Fuel. **89**(8): p. 1749-1762.
24. Lyngfelt, A., B. Leckner, and T. Mattisson, *A fluidized-bed combustion process with inherent CO₂ separation; application of chemical-looping combustion*. Chemical Engineering Science, 2001. **56**(10): p. 3101-3113.

25. Johansson, M., T. Mattisson, and A. Lyngfelt, *Investigation of Mn₃O₄ With Stabilized ZrO₂ for Chemical-Looping Combustion*. Chemical Engineering Research and Design, 2006. **84**(9): p. 807-818.
26. Teresa Mendiara, A.J.a.P.G., *Chemical Looping Reforming of Generator Gas*. 2009, Department of Chemical and Biochemical Engineering: Lyngby, Denmark.
27. Glicksman, L.R., M. Hyre, and K. Woloshun, *Simplified scaling relationships for fluidized beds*. Powder Technology, 1993. **77**(2): p. 177-199.
28. Brage, C., et al., *Use of amino phase adsorbent for biomass tar sampling and separation*. Fuel, 1997. **76**(2): p. 137-142.
29. Pröll, T., et al., *Cold Flow Model Study on a Dual Circulating Fluidized Bed (DCFB) System for Chemical Looping Processes*. Chemical Engineering & Technology, 2009. **32**(3): p. 418-424.

