



**CHALMERS**  
UNIVERSITY OF TECHNOLOGY



Chalmers University of Technology

# **Axial flux machine as a traction motor for electric and hybrid vehicles**

**MIKAEL ALATALO**

DEPARTMENT OF Electrical Engineering

---

CHALMERS UNIVERSITY OF TECHNOLOGY

Gothenburg, Sweden 2018

[www.chalmers.se](http://www.chalmers.se)

# **Axial flux machine as a traction motor for electric and hybrid vehicles**

© M. Alatalo 2019

Technical report 2018:1  
Department of Electrical Engineering  
Division of Electric Power Engineering  
CHALMERS UNIVERSITY OF TECHNOLOGY  
SE-412 96 Gothenburg  
Sweden, 2018

Cover page: Yokeless axial flux machine

## Abstract

Permanent magnet synchronous motors are often used in drive trains for electric and hybrid vehicles. The Division of Electrical Engineering at Chalmers University of Technology have done a work on different radial flux machines as traction motor. As a compliment axial flux machines are also added to the comparison. Together with the department of Environmental Systems Analysis, the different motors have also been objects for LCA calculations.

The radial flux machines have 8-poles and different magnet material have been evaluated. Compared to the radial flux machines a 16-pole axial flux machines have lower material weight but also lower efficiency. The high speed performance are also quite low, but an yokeless variant can have as high maximum efficiency as the best machines and about 50 % of the weight compared to the radial flux machines. The maximum efficiency is reached at higher torque compared to the radial flux machine so the overall efficiency over a drive cycle is lower for the axial flux machine. A solution with iron powder material has generally higher losses but if the iron core is made of high grade material and the size of the machines is changed, there is a possibility to make a good machine for propulsion of electric vehicles.

# Axial flux machine as a traction motor for electric and hybrid vehicles

## **Content**

1. Axial flux machine compared to radial flux machine.....	6
2. Different types of axial flux machines.....	9
3. Machine dimensioning.....	13
3.1 Result from calculations on one segment.....	13
4. Discussion.....	18
5. Core material.....	20
6. Losses in the magnet.....	23
7. Axial flux machine with extended pole faces.....	24
7.1 Calculations on machine with extended pole face.....	24
8. Conclusions.....	28
9. Future work.....	29
10. References.....	30
Appendix A. 16 Pole radial flux machine	
.....	
33	
Appendix B. Yokeless machine	
.....	
35	
Appendix C. Main machine data	
.....	
36	

## **1. Axial flux machine compared to radial flux machine**

The axial flux machine have benefits and drawbacks compared to the radial flux machine and a lot of research activities have studied different aspects of the axial flux machine, [1]. Capponi et.al. have reviewed the progress in analysis and development of axial flux machines the last decade. The review includes axial flux machine types, electromagnetic and thermal modelling, manufacturing issues, torque quality and extended speed range. Comparisons between axial flux machines and other types are also highlighted. Both positive and negative results are shown so no general conclusion can be drawn but it's clear that low weight can be achieved with the axial flux machine.

Two high performance machine are worth mentioning as traction motors, the Yasa-motor, [2, 3] and the EVO-machine, [4]. Booth have short axial length and high torque to weight ratio. One example is the Yasa400 which can produce 360 Nm peak torque and continuous torque of 250 Nm from a machine that weighs 24 kg. The Yasa-motor uses a yokeless stator in between two rotor parts. The EVO-machine has one rotor in between two stators. Magnax from Netherlands is a third company building yoke less axial flux machines. The machine is modular and the teeth are built with grain oriented laminations and rectangular copper wires. The low weight could be beneficial in a LCA-study.

The radial flux machine with interior rotor have a solid back iron core in which slots are punched, see Figure 1. This result in a mechanically strong construction. The magnetic forces in radial direction tend to even out. The forces on the bearings is mainly in radial direction which is beneficial for normal ball bearings. The power losses can be taken care of by cooling ducts in the motor housing, which is a convenient way to both cool the housing and stabilise the stator.

If we consider an axial flux machine with the same rating and a rotor part between two stator parts, there is obvious differences compared to the radial flux machine. The conductor length is distributed in the radial direction instead of the axial direction which is the normal situation in a radial flux machine. The active stator length is divided in two pieces which are placed on each side of the axial flux rotor, if we chose a double stator design. The rotor is shortened but the rotor has to magnetise two air gaps, i.e. the magnet thickness has to be doubled.

It's possible to build the axial flux machine both without stator yoke or without rotor yoke which is the main benefit of an axial flux machine. With a proper design the active parts may be placed on a bigger radius than the air gap radius of an radial flux machine. The draw back is that we have short active winding length and the amount of material in the end windings is higher. The end winding will also be a part of the machine radius. i.e. if we want to compare a radial flux machine to an axial flux the radius of the end winding has to be considered.

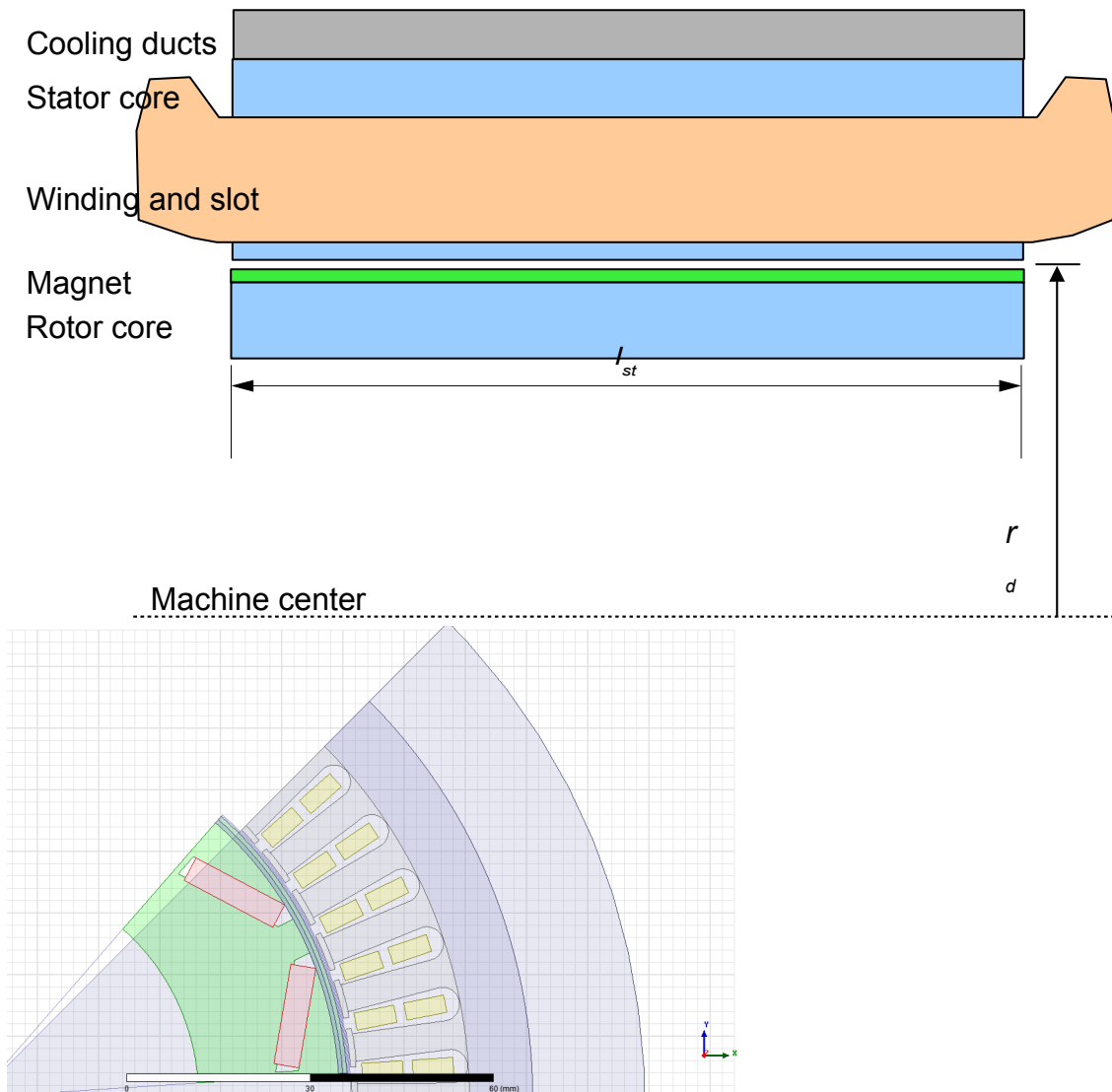

Figure 1. Radial flux machine arrangement, side view and axial view of one eighth of a machine.

The end windings of an axial-flux machine is minimised when using concentrated windings and in that case it's quite easy to use rectangular conductors which increases the copper fill factor of the winding.

A radial flux machine with a long stator,  $l_{st}$  compared to the air gap radius,  $r_d$ , can be hard to replace with an axial flux machine. If the outer diameter is fixed the length of the conductors have to be placed from the outer radius inwards towards the centre of the machine. If the length of the original machine isn't much shorter than the radius, the machine parts have to be halved and placed on each side of a central rotor. This means in comparison to each winding of the radial flux machine that the axial flux machine have twice amount of end winding.

The pole pitch isn't constant for the axial flux machine and a certain flux density level in the tooth limits the inner radius. A small inner radius leaves small space for both tooth and slot which normally limits the inner radius to 0.6-0.7 of the outer radius.

An axial flux stator can be made of laminated sheets but the slots have different distance between each other depending on radius, which makes the punching of the slots special. A good alternative is

iron powder which is isotropic in all direction and can have an arbitrary shape. The anisotropic property can be utilised when stretching the pole shoe in radial direction and 'prolonging' the magnet.

## 2. Different types of axial flux machines.

The fundamental part of an axial flux machine is one stator and one rotor part, see Figure 2. In comparison to a radial flux machine the conductors are directed in radial direction and the magnet flux are changed to axial direction. If the radius is high and the machine is short they are almost equivalent as we will see later on.

The single stator and rotor concept has one serious drawback and that is the magnetic pull between stator and rotor.

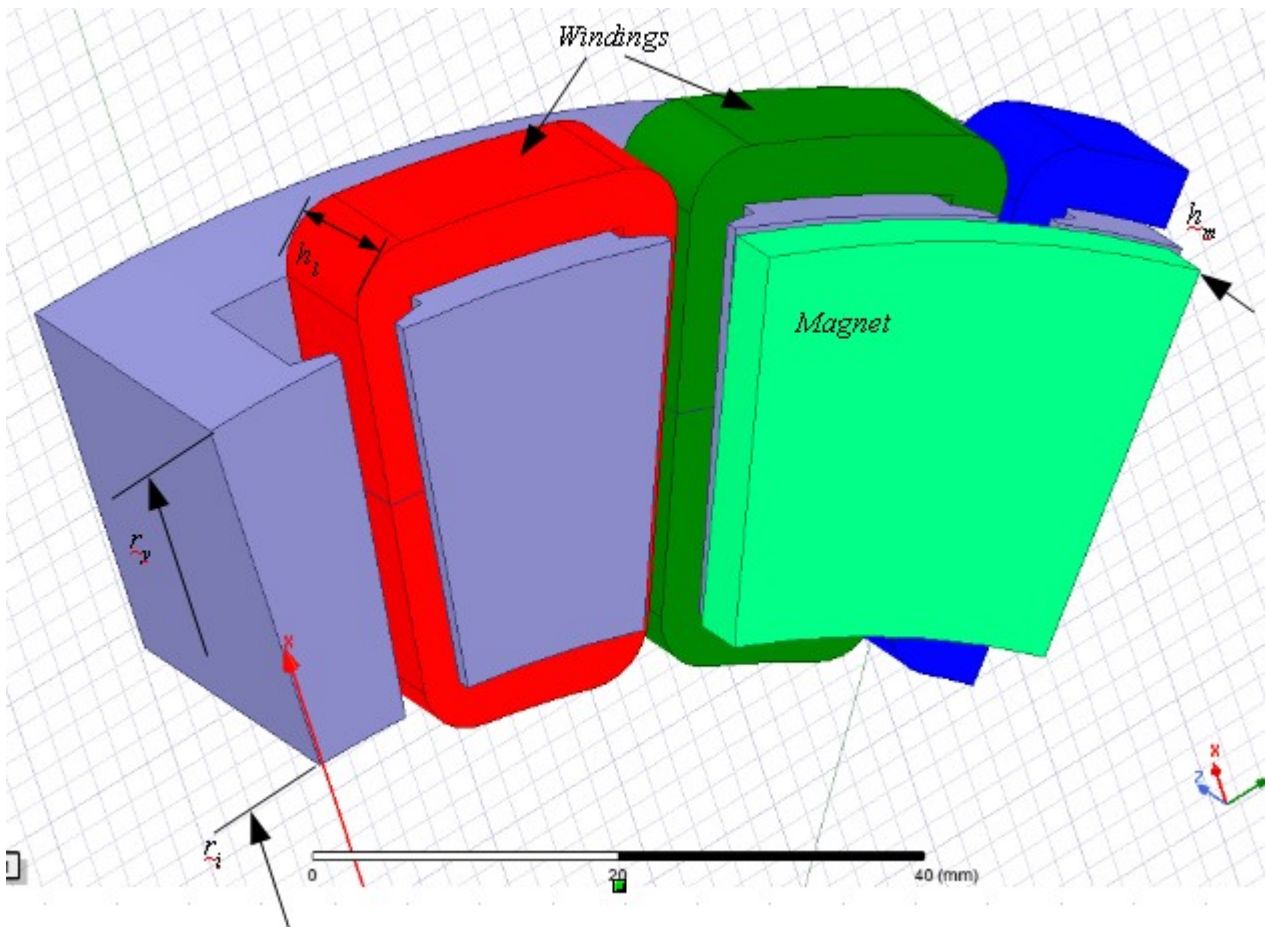

Figure 2. Section of an axial flux machine. Rotor yoke and left magnet hidden.

If the produced torque isn't enough from the single section it's possible to stack several sections in the axial direction. In figure 3 the rotor is placed in between two stator parts and the output can be doubled with the drawback of also doubling the end winding length. The benefit is that the rotor iron core can be skipped and the axial force is balanced between the two stator parts.

In the same way the stator may be placed between two rotor parts, see Figure 5, where four single sections have been stacked. A central stator has no stator yoke but has to be cooled in another way. [2]. The losses in the stator yoke is also avoided which is beneficial.

The winding of an axial flux machine can be made in the same way as radial flux machines but a



distributed winding takes more place and also extends the machine in radial direction due to more copper in the end winding. A concentrated winding is more handy to use without crossing of end windings from different phases: So of that reason the concentrated winding is evaluated in this report.

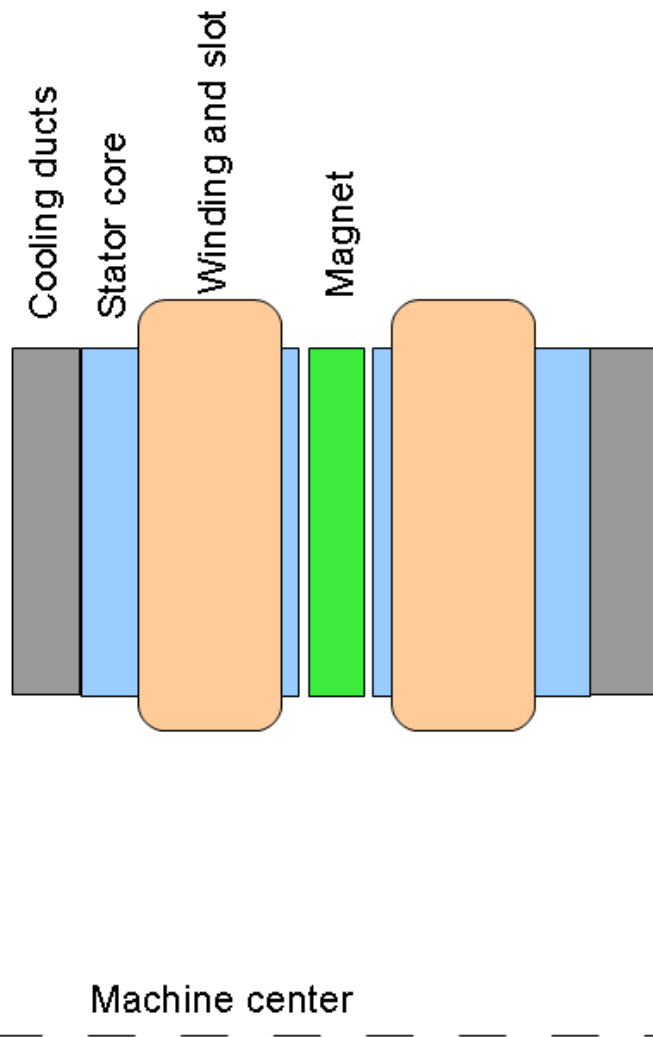

Figure 3. Axial flux machine arrangement cross section

The draw back of concentrated windings is that the flux from the winding is non-sinusoidal which produces losses in the magnet. Slicing the magnet in thin pieces lowers the losses, which mainly is a problem of over-heating the magnets, which is a problem that has to be addressed.

The axial flux machine in Figure 3 isn't capable of producing the same torque as the radial flux machines we have compared to without increasing the radius. In order to increase the output of the machines the parts in Figure 3 can be multiplied. As a start it is assumed that the cooling of the axial flux machine is similar to the radial flux machine cooling. I.e. the heat is transported through the iron core to a cooling arrangement outside of the stator core. See Figure 4.

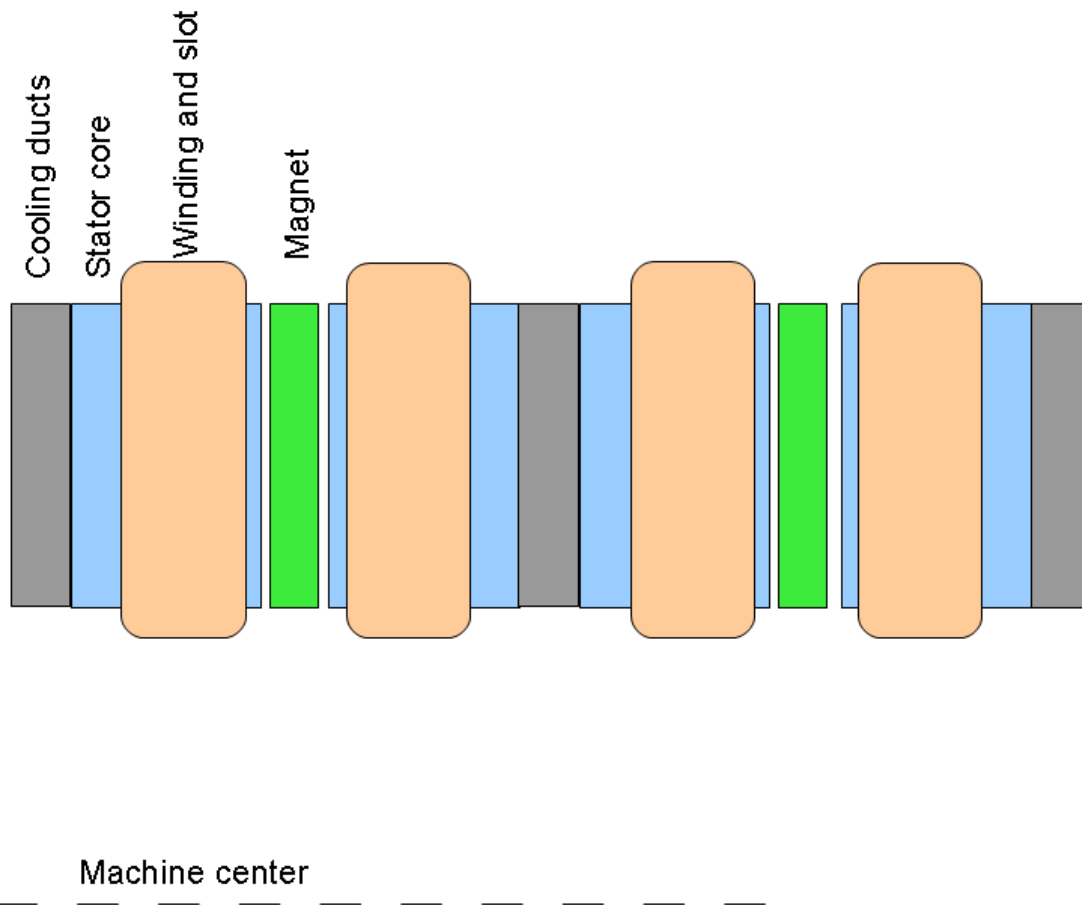
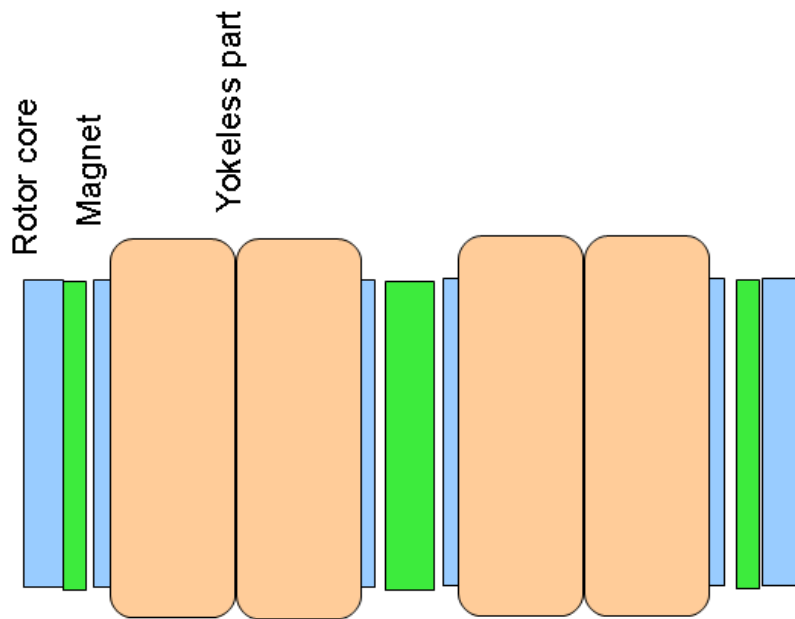

Figure 4. Multiplied axial flux machine, cooling ducts in between the segments.

It's possible to use a so called yoke-less construction [2] when multiplying the axial flux parts but in that case the cooling arrangement has to be altered for the parts in between the outer stator segments. A way of manufacturing and fixing the stator parts is described in [3]. The yoke-less construction is however attractive due to low iron core weight.

An alternative way of making the winding is the toroidal winding, which is described by [1] and it also makes it possible to make a machine in between radial flux and axial flux machine,[6,7]. The possibility of making a distributed winding as in [6,7] is of course attractive but it's hard to make use of this construction due to high flux in the centre part if rare-earth magnets are used but if ferrite magnets are used it's a good way to concentrate the flux.

Another way of utilising flux in both axial and radial flux direction is described in [5] where the relatively low flux density from ferrite magnets can be concentrated into a yokeless winding.



Machine center

Figure 5. Two section of the yoke-less axial flux machine.

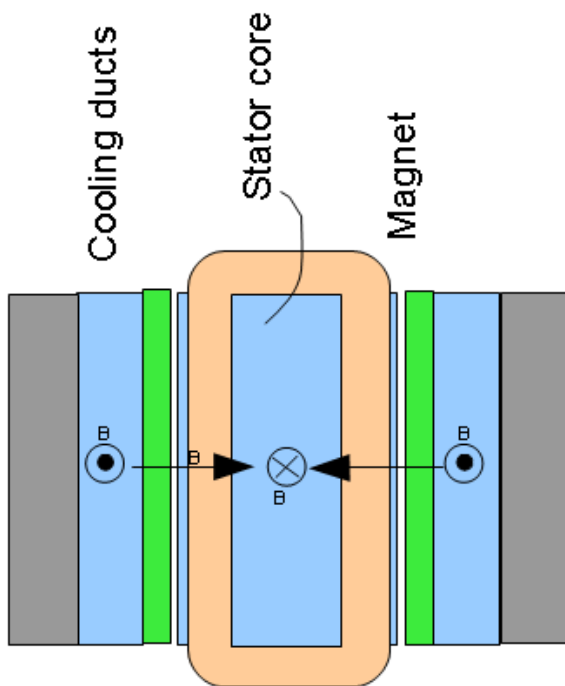

Figure 6. Gramme-ring stator or toroidal winding

The Gramme-ring stator has a winding that is toroidal, i.e. the winding enclose the core of the

stator. Magnets push flux into the centre stator from both directions and the flux has to turn around in the centre part. The construction can be utilised with magnets pushing in from several sides, [6,7], if the stator part can be mounted in an appropriate way and if the core material is magnetically isotropic.

### 3. Machine dimensioning

As a start an axial flux segment with iron powder material and core diameter of 200 mm is analysed. The intention is to use one solution with three rotors so the analysis is done on one sixth of the machine. The end windings will extend the diameter to 210 mm which is considered reasonable compared to the radial flux machines. The axial-flux machine have a cooling circuit connected to the core according to Figure 4.

#### 3.1 Result from calculations on one segment

The total flux as function of the current from one segment of the axial flux machine is displayed in Figure 7. The flux will form ellipses in the current plane with a centre lying to the left of maximum current in negative d-direction. This results in a machine that cannot be completely demagnetised by normal currents.

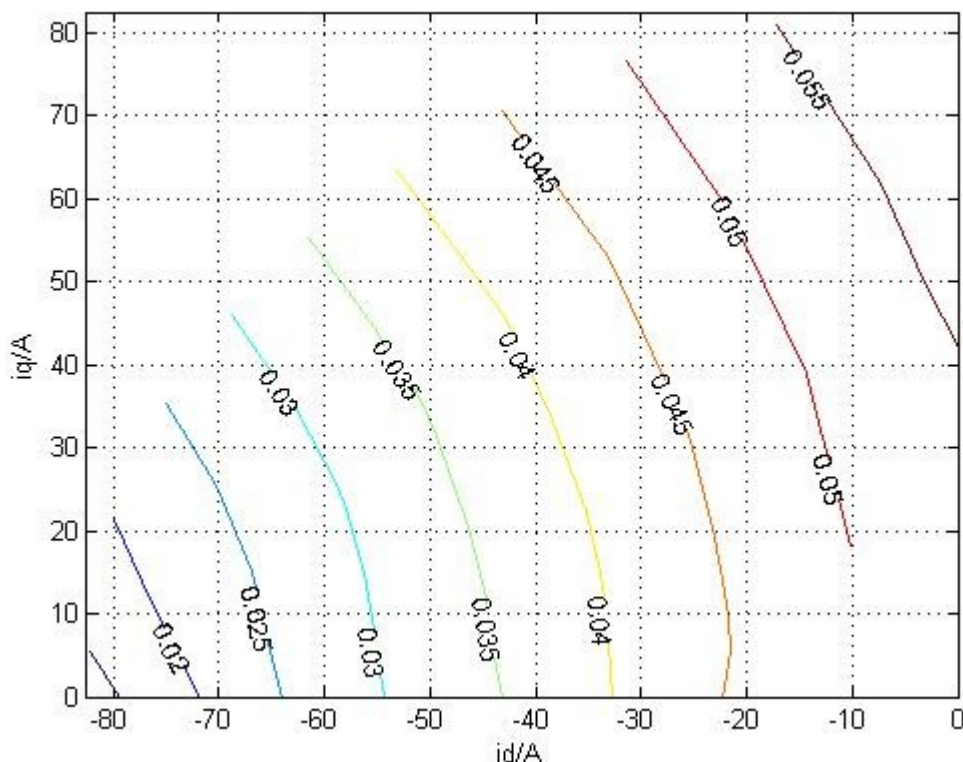

Figure 7. Flux contour lines, flux RMS-value

The maximum flux corresponds to a DC-link voltage of 455 V at 4000 rpm. In the other machines it has been assumed that the DC-link voltage is 400 V. This can be easily fixed if  $N_q = 15$  instead of 17. Changing the number of turns doesn't affect efficiency figures if the fillfactor is constant.

The torque from one segment of the motor is shown in Figure 8.

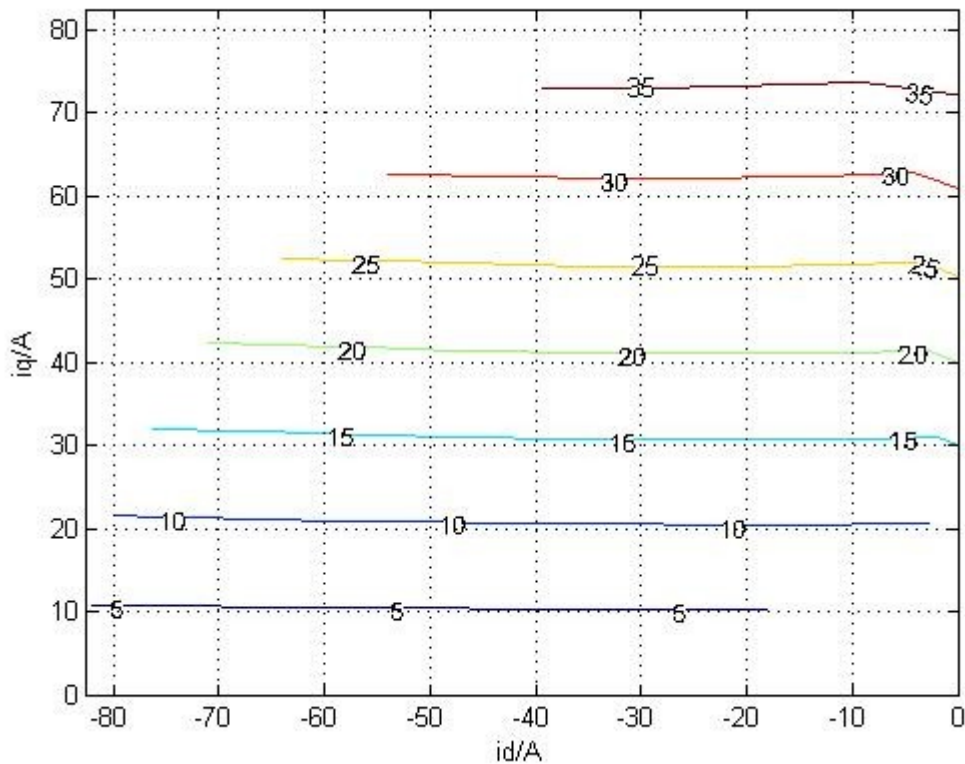

Figure 8. Torque at different d and q-current.

The losses at different speeds and torques are calculated and put together, see Figure 9, where it is obvious that the torque capability at high speed isn't that good. The torque at max speed drops to 20 Nm which is quite weak. The best rare-earth machines produce 70-80 Nm at 12000 rpm so there's a lack of performance.

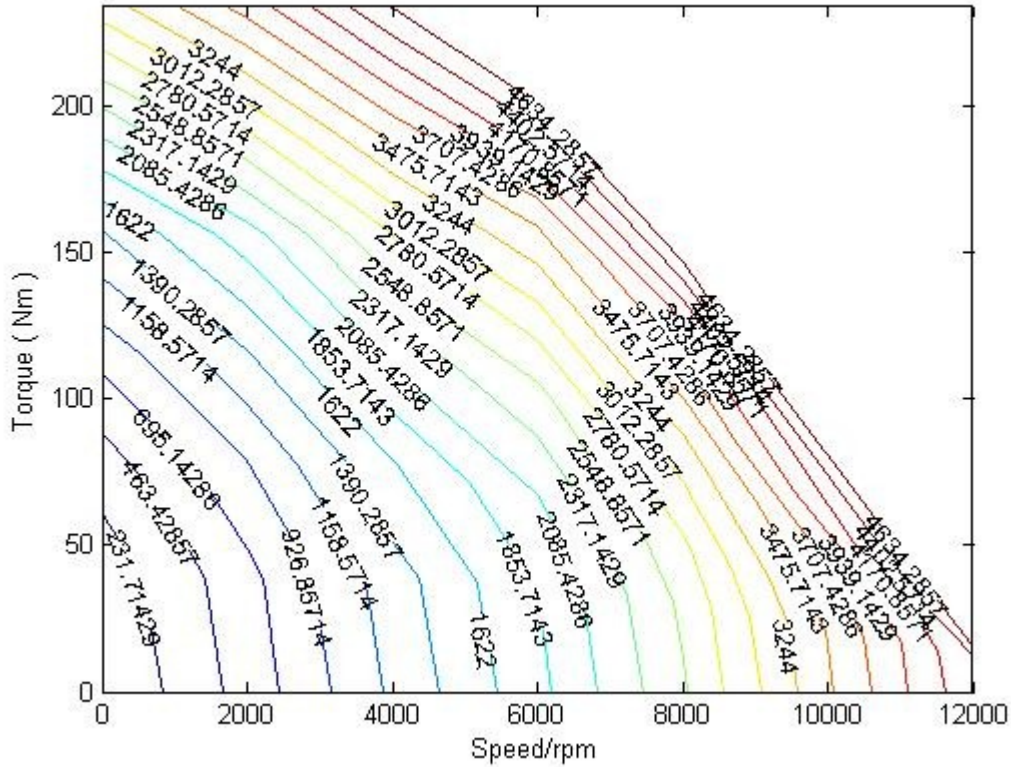

Figure 9. Losses in the machine, six segments.

In order to make a comparison to three 8-pole machines, one ferrite magnet machine and two rare-earth radial flux machines, are evaluated in [9,11], it is decided that the outer diameter of the core is 200 mm. The peak torque is 239 Nm, power 100 kW and top speed at 12000 rpm. An axial flux machine is added to the comparison as well as a radial flux machine with 16 poles and concentrated windings. The main data are shown in Table 1. The comparison between a 16-pole and 8-pole isn't fair but as a reference to the axial flux machine with 16 poles it's interesting to make this comparison.

The tooth and yoke is tuned so that the no-load flux density in both parts are 1.5-1.55 T and the slot depth is tuned so that the current density is 20 A/mm<sup>2</sup>. I.e. the machine isn't optimised but adapted to similar situation as for the radial flux machines. Core length of the 16 pole radial flux machine is the same as for the smallest of the 8-pole machines, 127 mm. In order to produce the total torque with the axial flux machine it is necessary to use  $N_{ax} = 6$  single segments.

Table 1. Mechanical data of the axial flux machine, see also Appendix A

Parameter	Value	Unit
Outer diameter, $D_y$	200	mm
Inner diameter, $D_i$	144	mm
Slot width, $b_{sl}$	12.4	mm
Slot depth, $h_l$	9.6	mm
Magnet thickness, $h_m$	5 (2.5 per stator half)	mm

<b>Parameter</b>	<b>Value</b>	<b>Unit</b>
Magnet embrace, $b_m / b_p$	0.9	-
Magnet material	Hitachi NMX-37	
Air gap, $d$	0.7	mm
Stator yoke thickness, $h_{sy}$	7	mm
Outer dia. Incl. End winding	210	mm

In Table 2 the weights of different alternative are displayed. The first machine is a machine with three double stator axial flux machine, according to Figure 4. The last one is a Yoke-less machine according to Figure 5, with three rotors.

Table 2. Weight of materials, ( kg )

Mass/kg	3 axial flux	Radial flux 16 poles	'Yoke-less'
Stator core weight, $m_{fes}$	8.74	6.9	4
Rotor core weight, $m_{fer}$	0	2.47	1.6
Magnet weight, $m_{Nd}$	1.61	0.88	1.61
Copper weight, $m_{cu}$	4.28	3.2	4.28
Total weight, $Mass$	<b>14.4</b>	<b>13.5</b>	<b>11.5</b>
Machine length, $l_{ma}$	189 mm	147 mm	103 mm
Efficiency @ 240 Nm 4 krpm	0.94	0.96	0.95

In Table 2, the weights of different machine alternatives are shown. A radial flux machine with 16 poles and the flux density similar to the axial flux machine and ditto current density weighs about one kg less compared to the axial flux machine. The magnet weight of the axial flux machine is also quite high. If we consider the same cooling arrangement the radial flux machine is preferred.

There is a possibility to produce a lighter machine compared to the radial flux machine and that is to use the yoke-less machine alternative for the sections that are in between the outer parts, see resulting weights in Table 2, last column. In that case the cooling arrangement and mounting of the stators that are 'hanging' in between rotors have to be solved. In the first axial flux machine the stators are mounted to an aluminium flange that both supports the stator mechanically and serves as cooling arrangement. The machine in Figure 5 has the same amount of active parts but both the stator yoke and the cooling doesn't add to the axial length, which makes it compact and the lack of yoke in the stator lower the losses of the machine.



## 4. Discussion

The pole area can be increased if stretching the tooth front facing the airgap, not only in tangential direction but also in radial direction, see Figure 10.

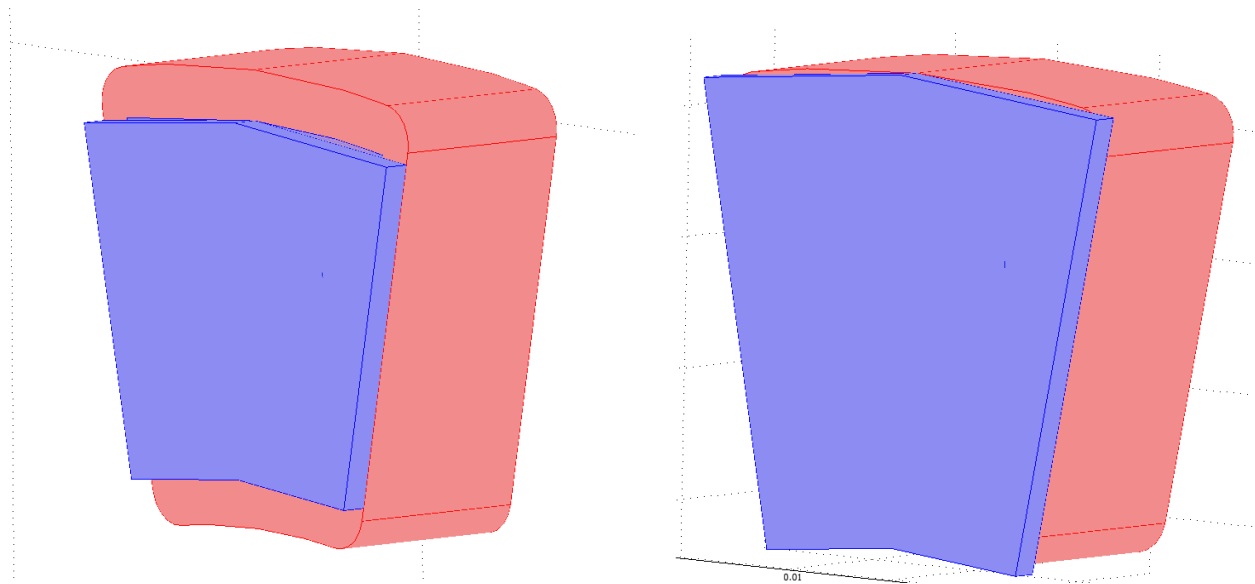

Figure 10. Increased pole area to the right

Ideally the pole area may be increased by a factor of 42 % if we change the magnet radius from 100 to 106 mm and the inner radius to 66 mm. However the increased pole area will increase the magnet flux which has to be met with an increased area of the central part of the tooth, if the flux density shall be constant. The flux density from the beginning was 1.6 T and if we increase the flux with 42 % the flux density in the middle part of the tooth has to increase to 2.24 T. The latter figure is too high for the iron powder material which means that the flux density in the tooth has to be balanced to the tooth area.

In order to utilise the increased flux from the increased pole area the winding must be thinner, slot width is decreased from 12.4 to 10 mm, but further decrease of slot width lowers the output. The possible output from one machine part will increase with a factor of 1.32 ( according to Maxwell). i.e. in order to produce the output power it's possible to settle with 4.6 machine parts ( fractional machine parts is of course not an option but for evaluation reasons it is allowed). The length of the yoke-less construction with extended pole area is 92 mm, i.e. this technique makes it possible to make a shorter machine. The losses at 4000 rpm will decrease from 4600 W to 4400 W, due to lower copper losses, i.e. the peak efficiency is as good as the radial flux machine. The no load losses will however increase from 1200 W to 1680 W and the magnet weight is almost the same as in the other axial flux machines.

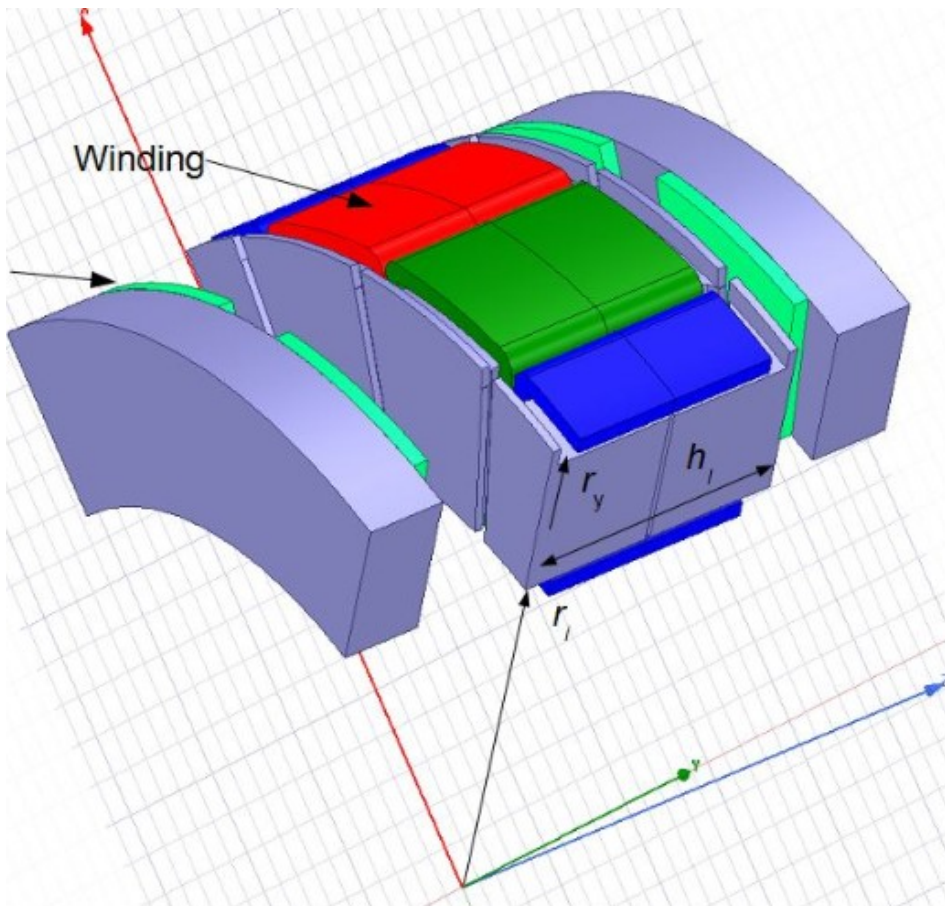

Figure 11. View of yokeless machine.

The best is of course to optimise the machine for one operating point or the whole drive cycle, i.e. make up one cost function for material and losses. The optimised axial flux machine can in that case be compared to a radial flux machine. It doesn't look so good for the axial flux machine as long as we have limitation on the radius, the copper weight and the magnet weight is higher compared to the radial flux machine. Using yoke-less stator parts compensates partly for the higher copper loss in the axial flux machine and the machine can be shorter than the radial flux machine.

## 5. Core material

In the radial flux machine the flux trajectory is directed in radial and tangential direction. In an axial flux machine the pole width varies with the radius and of that reason it is not a simple task to produce a lamination for the axial flux machine. As the pole pitch increases with the radius the distance between the slots will vary along the lamination length, which will be rolled to form the stator core.

The axial flux machine is preferably built using iron powder material, which have the same characteristics in all directions. In the study the material Somaloy 1000 have been used.

The iron powder is not as good as ordinary laminations but at high frequency for example at 1000 Hz, the Somaloy material has twice the losses compared to M250-35 which is quite good especially if we consider that stamping and producing laminations will degrade the material. The eddy current losses are also lower and the machines used for traction have considerable amount of harmonics both in induced voltage and flux density waves.

At high current rating the material will have lower saturation flux density which will result in lower maximum torque. In this construction with surface mounted magnets we have to use high current level and the difference is not so disturbing for the current density we use in this report. See Figure 12, where the torque is calculated for one segment of the axial flux machine. We need to use twice the maximum torque to see big differences between the iron powder material and the lamination.

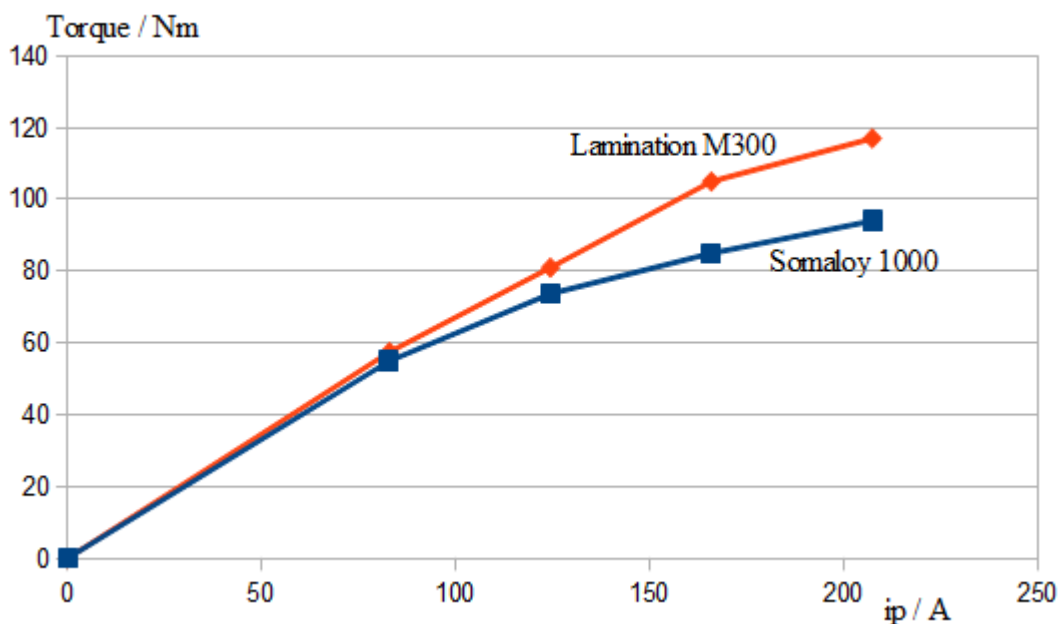

Figure 12. Torque from one segment at different current.

As a comparison the machine with extended poles that is evaluated later in this report are evaluated with N20-material, i.e. slightly better material than in the radial-flux machines. The resulting figures are displayed in Table 3.

Table 3. Iron core losses at different material choice and 22 A/mm<sup>2</sup>.

	Somaloy 1000	Cogent NO20
Torque, 4000 rpm, $i_q=I_{max}$	67 Nm	72.5 Nm
Eddy losses rpm	70 W	75 W
Hysteresis losses	170 W	70 W
Excess losses	40 W	30 W
Iron core losses	280 W	175 W
Torque, 12000 rpm, $i_d=-I_{max}$	0.0 Nm	0.0 Nm
Eddy losses 12000 rpm	230	170 W
Hysteresis losses	150	60
Excess losses	80 W	65 W
Iron core losses	460 W	295 W



## 6. Losses in the magnet

A concentrated winding produces a lot of space-harmonics in the airgap, which will try to penetrate the magnet. As long as the magnet has a conductivity a current will be produced with opposing flux that will try to minimise the penetrated flux. The current will produce losses due to ohmic resistance and we will have problems with heating of the rotors.

The losses in the magnet is calculated for 4000 rpm and max torque and the resulting loss is approximately 2000 W and it increases to 3600 W at 8000 rpm. It is by no means negligible so it has to be dealt with either using a magnet material with increased resistivity or dividing the magnet in smaller pieces, [10]. According to Lundmark and Poopak [10] the losses in the magnets decrease with the power of 2 of the number of slices that is imposed on the magnet. A reasonable figure of the mean rotor losses are  $< 100$  W which means that the magnet has to be divided in order to lower the rotor losses with a factor of 20-30.

Dividing the magnet into smaller pieces will lower the eddy currents to a level that doesn't influence the efficiency of the machine. For instance dividing the magnet in 6 times 3 pieces lower the losses at 4000 rpm to 128 W.

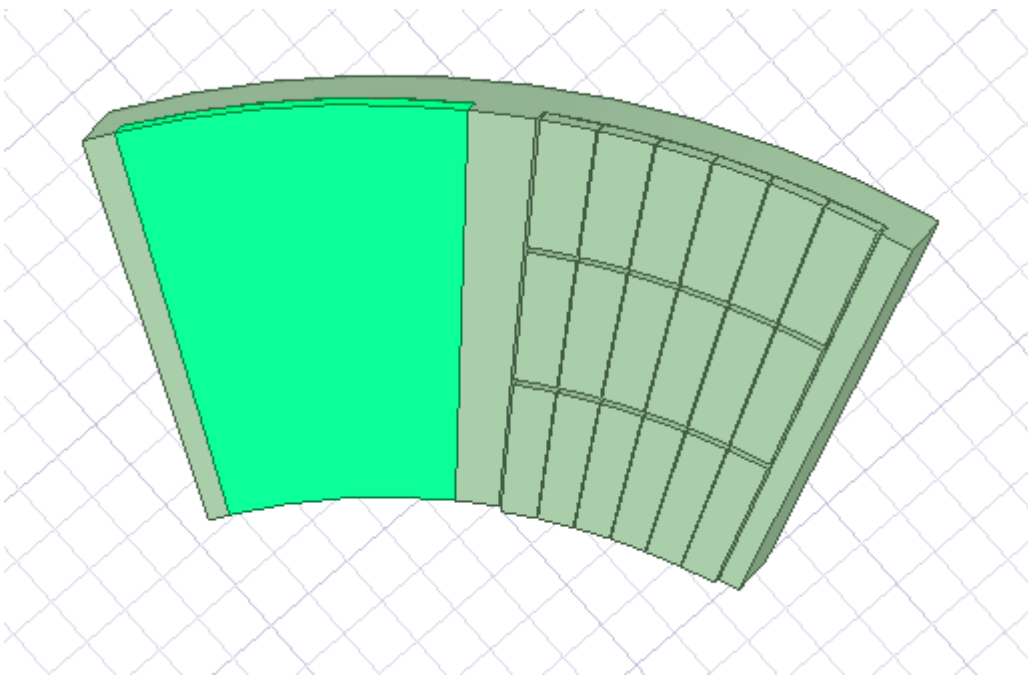

Figure 13. Original magnet to the left and the divided magnet to the right.

## 7. Axial flux machine with extended pole faces.

An axial flux machine with extended pole faces are evaluated, see Figure 14, where the main part is shown. The machine has a yokeless stator which means that it has to have supporting structures that also makes it possible to fix the stator to the housing. This is not solved in detail but material are added for supporting the stator structure and also for cooling of the stator. The cooling is not evaluated but a duct for cooling fluid is directly placed on the outer radius of the end winding. The end winding will produce an alternating field that will produce eddy currents in the duct if it is made of conductive material. Of that reason it is made of plastic material, with as low wall thickness as possible. The wall thickness will impose some challenges considering that there can be several kW of losses that shall pass this barrier. The wall thickness should be some tens of mm's and the thermal conductivity should be at least 5 W/mK.

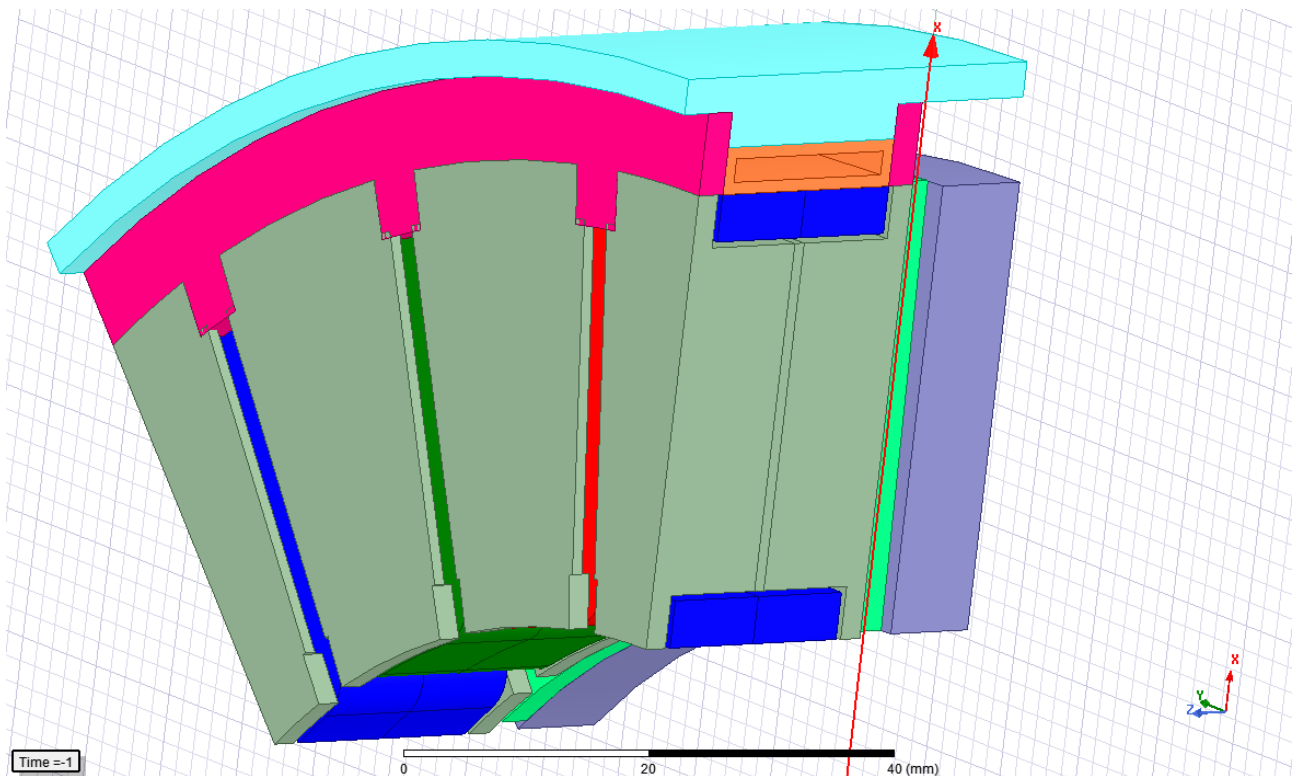

Figure 14. Enhanced axial flux machine with supporting structure of the stator. Red plastic material that holds the stator in place to the housing ( light blue). Orange is a duct for liquid cooling.

### 7.1 Calculations on machine with extended pole face

One stator rotor combination produces 56 Nm so in order to reach 240 Nm we will need 4.29 segments, if we can consider fractions of a machine. It could be motivated for comparative reasons. It can do with 4 segments but with lower efficiency and higher current density compared to the radial flux machines. The weight of the machine with 4.29 and 4 segments are summarised in Table 4. The torque at maximum speed is better in this machine compared to the one in section 7, due to higher inductance resulting in more q-current at maximum speed.

Table 4. Weight of the machine assuming 4.29 and 4 sections

Mass/kg	3 axial flux from earlier	'Yoke-less 4.29'	Yoke-less 4
Stator core weight, $m_{fes}$	8.74	3.9	3.6
Rotor core weight, $m_{fer}$	0	2.65	2.47
Magnet weight, $m_{Nd}$	1.61	1.54	1.44
Copper weight, $m_{cu}$	4.28	2.79	2.6
Total weight, $Mass$	<b>14.4</b>	<b>11.6</b>	<b>11</b>
Machine length, $l_{ma}$	189 mm	114 mm	105 mm
Efficiency @ 240 Nm 4 krpm	0.94	0.97	0.96
Nax		'4.29'	4

Additionally to the axial flux machine with central stator we have to add a material that fix the stator to the housing as indicated in Figure 15. The housing is made of aluminium .

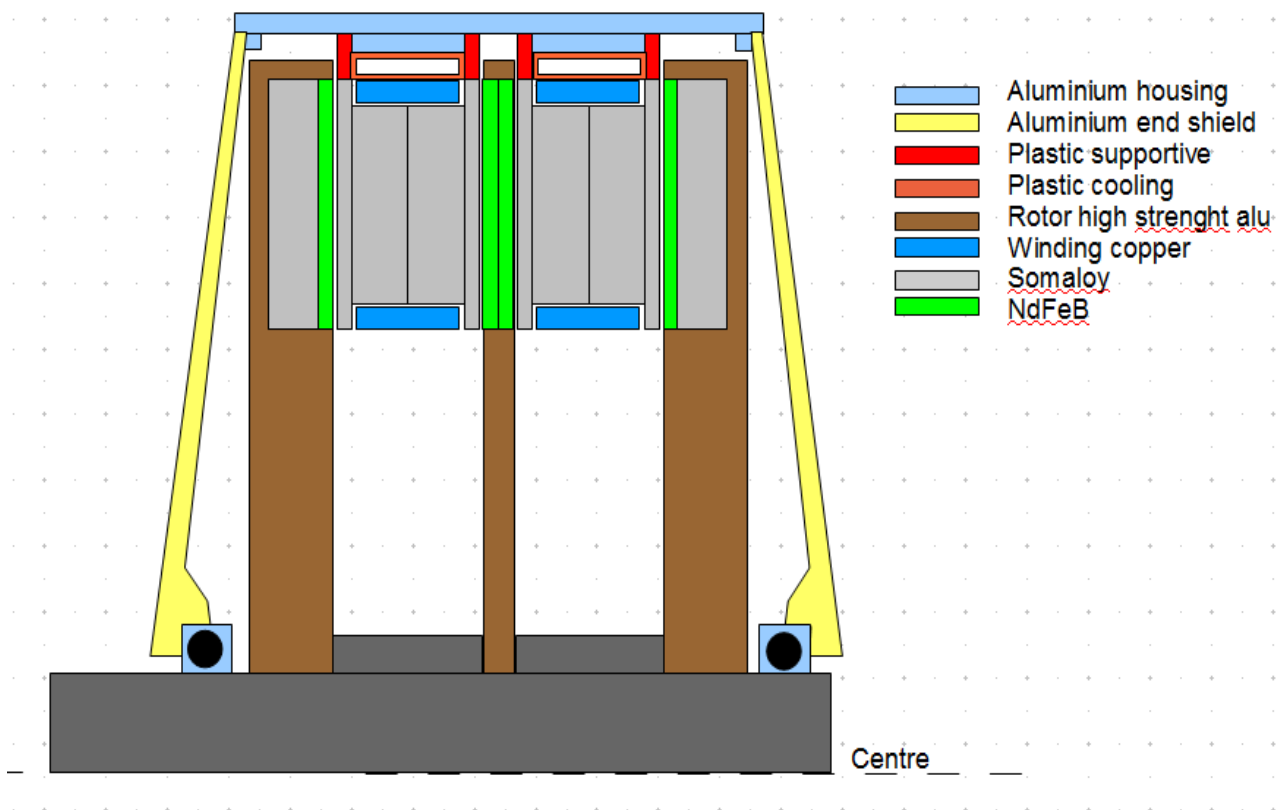

Figure 15. Axial flux machine. Three rotor discs and two yokeless stators



The machine performance is evaluated by means of extensive FEM-calculations at 4000 rpm and for the max torque and the speed 6,8,10 and 12 thousand rpm. From that data a more dense matrix of data is produced from approximative current and iron core losses. The machine is quite linear in the operating area so linear inductance is quite sufficient. And the iron core losses are approximately

$$P_{fe} = f(\Psi)g(\omega) \quad (1)$$

Where the function  $f$  depicts the losses for different absolute flux in the machine. For different speed the function  $g$  is a factor that depends on speed, see Figure 16. From the FEM-calculated data it is found that,

$$f(\omega) = a_3 \Psi^3 + a_2 \Psi^2 + a_1 \Psi + a_0$$

$$a_3 = 16204$$

$$a_2 = 2922$$

$$a_1 = 211$$

$$a_0 = 60$$

$\Psi$  absolute value of the flux / Wb

(2)

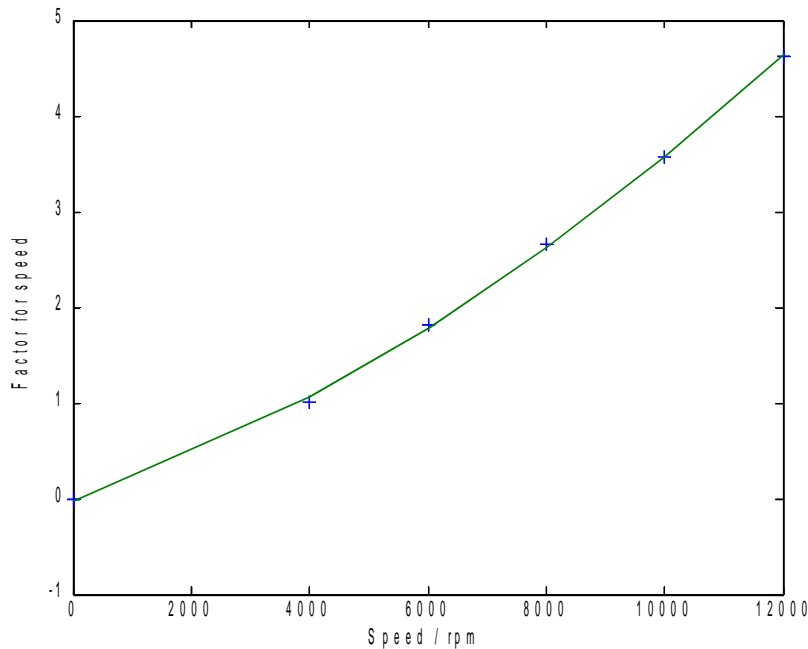

Figure 16. Normalised iron core losses,  $g(\omega)$

The factor for speed is used when calculating the iron core losses. In Figure 16 it is shown that the losses are evaluate at 4000 rpm and then scaled with the factor at other speed. The model normally

doesn't work well at high speed and high degree of field weakening but it works well in this machine. Probably due to low eddy current losses in the Somaloy material.

The motor parameters are:

$$L_d=1.70 \text{ mH}$$

$$L_q=1.57 \text{ mH}$$

$$\psi_m=0.128 \text{ Wb}$$

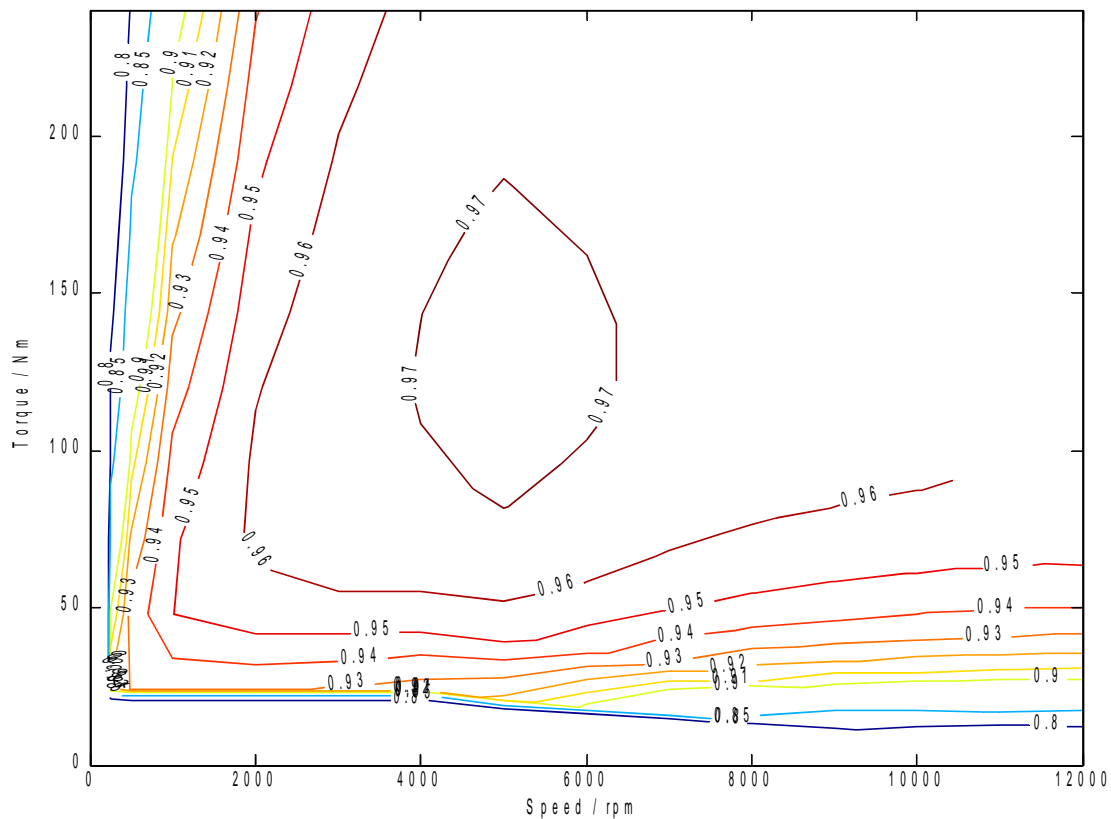

Figure 17. Efficiency of the evaluated axial flux machine

This machine is further analysed when used in a car and drive cycles. LCA-calculations are also done. The main performance problem is that the peak efficiency is concentrated to rather high torque. The best radial flux machines have higher efficiency at lower torque and this could be addressed if better iron core material is used.

Preliminary data from evaluating drive cycles shows that the losses are higher in both the winding and in the core. Using a better core material, see chapter 6, could make the core losses comparable to the losses in the radial flux machine but it is also necessary to lower the losses in the winding, which isn't possible using the constraints that are put on this machine.

A change of material isn't fully investigated but one point that is quite in the middle of the operational points of the driving cycle WLTP shows a decline in core losses of 100 W. The operating point is 4000 rpm and 50 Nm and in order to make this compatible it is not enough. A further decrease of pole numbers and lowering of flux density can provide a machine that is compatible but this is placed as future work.

## **8. Conclusions**

Axial flux machines has been evaluated and compared to radial flux machines. The solution with a central stator shows the most promising result, but it has both higher core losses and winding losses compared to a radial flux machine with NdFeB-magnets. Changing the core material could lower the core losses to comparable values as the core losses in the radial flux machine. This isn't considered as enough, measures has to be taken in order to lower the winding losses as well. The weight is considerable lower of the axial flux machine.

A solution with four segments could have similar torque-speed performance as the radial flux machine but the cooling arrangement of this machine isn't solved neither is the mechanical construction of the stator.

The comparison is made under the restriction that the machines shall have the same radius and current density. An opening for the axial flux machine could be to increase the radius and use two rotor segments and one stator as well as using a better core material.

## **9. Future work**

A lot of interesting topics can be found in the axial flux machine and especially in two of them.

The yokeless machine have good performance and two topics may be mentioned that is unsolved

- ⤴ Thermal solutions and performance
- ⤴ Manufacturing methods, how to mount the stator pieces to a solid stator that can be fixed to the housing.
- ⤴ Evaluate a solution with better iron core material.
- ⤴ Study how radius and pole number influence the result

## 10. References

- [1] Capponi, deDonato, Caricci 'Recent Advances in Axial-Flux Permanent-Magnet Machine Technology', IEEE TRANSACTIONS ON INDUSTRY APPLICATIONS, VOL. 48, NO. 6, NOVEMBER/DECEMBER 2012
- [2] Camilleri. Woolmer, et.al. 'Investigation into the temperature profile of a liquid cooled YASA © AFPM Machine' 6th IET International Conference on Power Electronics, Machines and Drives (PEMD 2012)
- [3] Zhang, Seidler, et.al. 'Development of a Yokeless and Segmented Armature Axial Flux Machine', IEEE TRANSACTIONS ON INDUSTRIAL ELECTRONICS, VOL. 63, NO. 4, APRIL 2016
- [4] <https://avidtp.com/product/evo-motors/>
- [5] Liu, Wang, et.al.'Performance analysis of a new radial-axial flux machine with SMC cores and ferrite magnets', AIP ADVANCES 7, 056603 (2017)
- [6] Shimomura, Shoji; Sunaga, Takatoshi ,'Design of integrated radial and dual axial-flux ferrite magnet synchronous machine', 2016 IEEE Energy Conversion Congress and Exposition (ECCE), 2016
- [7] Ozeki, Shimomura,'Comparative Study of Integrated Radial-Axial Flux rotor motor using Ferrite Magnet', ICEM 201
- [8] D. A. González, J. A. Tapia, R. Wallace, and A. Valenzuela, "Design and test of an axial flux permanent-magnet machine with field control capability," *IEEE Trans. Magn.*, vol. 44, no. 9, pp. 2168–2173, Sep. 2008.
- [9] A. Nordelöf et.al.' A scalable life cycle inventory of an electrical automotive traction machine—part II: manufacturing processes' *The International Journal of Life Cycle Assessment*, pp 1-15, 2017
- [10] Lundmark S. Poopak R. 'Two-Dimensional and Three-Dimensional Core and Magnet Loss Modeling in a Radial Flux and a Transverse Flux PM Traction Motor', IEEE TRANSACTIONS ON INDUSTRY APPLICATIONS, VOL. 53, NO. 3, MAY/JUNE 2017
- [11] Lundmark et.al.,'Three Traction Motors with Different Magnet Materials - Influence on Cost, Losses, Vehicle Performance, Energy Use and Environmental Impact', 2018 Thirteenth International Conference on Ecological Vehicles and Renewable Energies (EVER)

DEPARTMENT OF Electrical Engineering  
CHALMERS UNIVERSITY OF TECHNOLOGY  
Gothenburg, Sweden  
[www.chalmers.se](http://www.chalmers.se)



**CHALMERS**  
UNIVERSITY OF TECHNOLOGY



**Appendix A. 16 Pole radial flux machine**

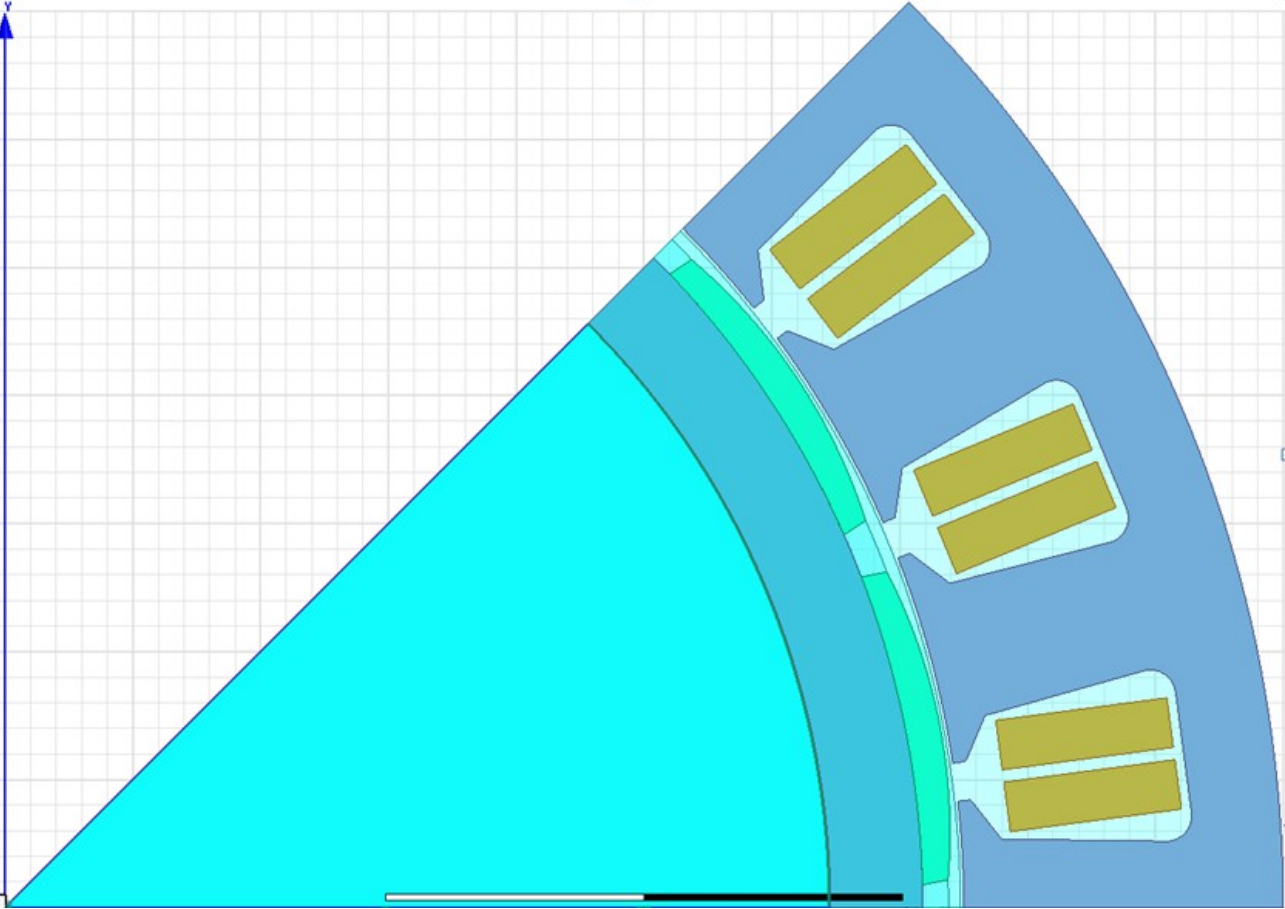





# Appendix B. Yokeless machine

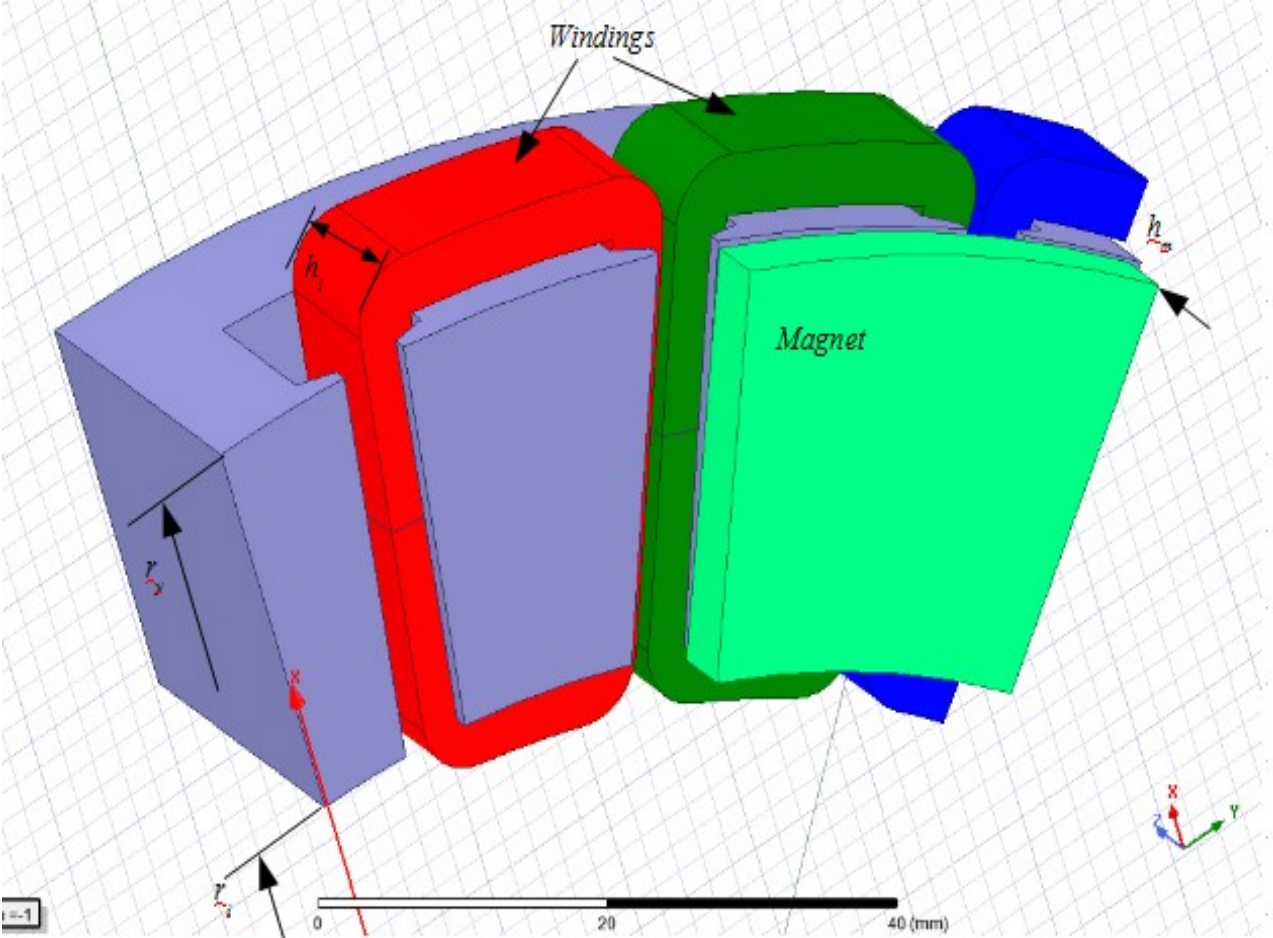

## Appendix C. Main machine data

			Axial flux	Radial flux
$D_y$	Outer diameter	mm	210	200
$D_i$	Inner diameter,	mm	134	150
$r_d$	Air gap radius			149
$b_{th}$	Width of tooth	mm		10.7
$h_l$	Slot depth	mm	9.6	18
$b_{th}$	Magnet thickness	mm	2.7	2.7
$b_m$	Magnet width	-	84.00%	84.00%
$b_{sl}$	Slot width		10	
$d$	Air gap length	mm	0.5	0.5
$h_{sy}$	Stator yoke thickness	mm	7	7
$h_{ry}$	Rotor yoke thickness		7.3	7.3
$l_{st}$	Stator length	mm		127
$P$	Number of pole pairs		8	8
$Q$	Number of slots		24	24
$N_{ax}$	Number of axial single units		4	
$l_{ma}$	Total machine length	mm		145
$m_{fer}$	Rotor core weight	kg	2.5	2.9
$m_{fes}$	Stator core weight	kg	3.6	8.49
$m_{cu}$	Copper weight	kg	2.6	3.1
$m_{Nd}$	Magnet weight	kg	1.44	0.91
$Mass$	Total weight of active material	kg	11.5	15.4
$k_{cu}$	Fill factor of copper in slot		0.5	
$k_{fe}$	Fill factor of lamination		1 ( Somaloy)	0.95(NMX)
$b_p$	Pole width	mm		29.5