

A 183-GHz Schottky Diode Receiver with 4 dB Noise Figure

Martin Anderberg^{#1}, Peter Sobis^{#S2}, Vladimir Drakinskiy^S, Joel Schlee^{*}, Slavko Dejanovic[#], Anders Emrich[#] and Jan Stake^{S3}

[#]Omnisys Instruments AB, Gothenburg, Sweden

^STerahertz and Millimetre Wave Laboratory, Department of Microtechnology and Nanoscience–MC2, Chalmers University of Technology, Gothenburg, Sweden

^{*}Low Noise Factory AB, Gothenburg, Sweden

¹maan@omnisys.se, ²ps@omnisys.se, ³jan.stake@chalmers.se

Abstract—Atmospheric science based on space-borne millimeter wave measurements require reliable and state-of-the-art receivers. In particular, the water vapor line at 183.3 GHz motivates the development of sensitive mixers at this frequency. Traditional assembly techniques employed in the production of Schottky diode receivers involve flip-chip mounting and soldering of discrete dies, which prohibit the implementation of reliable and repeatable production processes. In this work, we present a subharmonic 183 GHz mixer implementing a repeatable assembly method using beamlead Schottky diodes. The mixer was integrated with a InP HEMT MMIC low noise intermediate frequency amplifier resulting in a record-low receiver noise temperature of 450 K at 1 mW of local oscillator power measured at room-temperature. The measured Allan time was 10 s and the third order local oscillator spurious power was less than -60 dBm. The proposed assembly method is of particular importance for space-borne missions but also applicable to a wide range of terahertz applications.

Keywords—Schottky diodes, heterodyne receivers, thin-film circuits, space instrumentation, front-ends, mixers, noise characterization, HEMTs, LNAs.

I. INTRODUCTION

Meteorological data is increasingly requested in order to gain deeper understanding of the mechanisms that drive climate change. Atmospheric research is dependent on space-borne remote sensing [1], in particular water vapor measurements since water vapor plays a major role in the Earth’s radiative budget [2]. By heterodyne detection of the 23.8 GHz spectral line or the 183.3 GHz spectral line the water vapor profile can be measured, where the latter is 10-100 more sensitive [3]. The importance of observations at 183.3 GHz drives the development of reliable and sensitive receivers capable of room temperature operation, for space-borne as well as for ground based instrumentation. Moreover, the increasing complexity of systems operating with multiple frequency channels demands for stringent requirements on spurious response and susceptibility to interference, which directly translates to stability and spurious emission. Schottky diode based receivers have shown to be robust and reliable with superior performance at terahertz frequencies [4] making Schottky technology the obvious choice in space applications.

Traditional Schottky mixers use flip-chip diodes in an inverted suspended stripline circuit topology [5]–[8] which prohibits post assembly visual inspection required for reliability qualification in space applications. Furthermore, the inverted circuit must be glued to obtain a dc-ground which introduces mechanical stress and thereby degrading the reliability further

as pointed out in [6]. Apart from the mixer implementation the receiver packaging is crucial in order to obtain key receiver performance in terms of stability and local oscillator (LO) spurious generation. The success of a mission is dependent on these performance parameters but are seldom presented.

This paper presents a 169.8 – 196.8 GHz Schottky diode receiver with state-of-the-art sensitivity. The receiver design is based on high reliability membrane integrated Schottky diode beamlead technology and assembly processes which have been subject to stringent ESA space qualification programs as part of the Jupiter Icy moon Explorer mission (JUICE) and the second generation Meteorological Operational satellite programme (MetOp). The receiver consists of a subharmonic GaAs membrane beamlead Schottky diode mixer that employs a non-inverted circuit topology, thereby enabling visual inspection of the circuit and diode anode. The circuit topology also offers robustness by avoiding the glued inverted substrate topology making it highly qualified for space applications. State-of-the-art receiver noise temperature is presented and short-term stability (Allan time) and third order local oscillator spurious power are characterized.

II. RECEIVER DESIGN

The receiver consists of a 183 GHz subharmonic Schottky diode mixer integrated with a 0.3 – 13 GHz InP MMIC low noise amplifier (LNA) as seen in Fig. 1. The mixer and the intermediate frequency (IF) LNA have been co-designed to a large degree by the implementation of a matching network which also includes the LNA gate bias. The LNA output is connected to a SMA connector using a 50 Ω transmission line. This is all integrated in the same mechanical housing including the amplifier bias control and protective circuit boards located in an inner and outer compartment with additional internal and external dc-feedthrough filters.

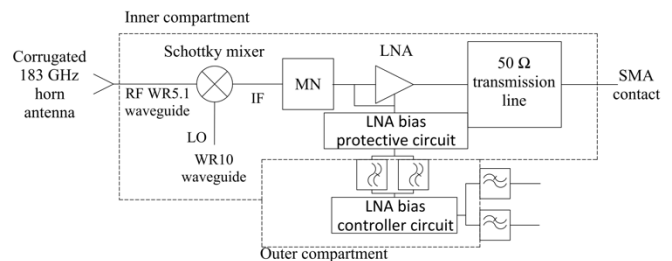

Fig. 1. Receiver architecture where the first detection stage is a subharmonic Schottky mixer followed by a matching network (MN) and a low noise amplifier (LNA).

A. Mixer Design

The subharmonic 183 GHz mixer is based on a hybrid circuit topology and is pumped with a LO frequency of 91.65 GHz. The mixer circuit utilizes high and low impedance sections plated on a 5488 μm long, 300 μm wide and 102 μm thick thin film quartz substrate mounted in a microstrip split-block channel using silver epoxy glue as seen in Fig. 2. A Smith chart is also presented where the optimum mixer circuit impedances at 183 GHz and 91.65 GHz are seen as blue and red diamond geometries respectively and are derived from the conversion loss contours. The silver epoxy is seen in grey and is applied onto the channel floor prior to substrate placement. Traditionally, mixers using long thin film quartz substrates have a degraded reliability due to mechanically stressed substrates. This is because the circuit is glued at the substrate edges but in this design the mechanical stress has been minimized by positioning the epoxy in the center of the substrate. Rectangular waveguides are used to couple the radio frequency (RF) signal and the LO to the anti-parallel diodes through E-probes centered in waveguides with reduced heights. The mixer topology is based on [9] where the diodes are located close to the RF E-probe. This minimizes the RF loss and thereby improves the conversion loss. To obtain a well-defined dc-ground, the anti-parallel diodes are suspended between the substrate and the mechanics by bonding one beamlead to the circuit and the other beamlead to a mechanical platform as seen in Fig. 3. The suspended diode topology provides visual inspection of the mixer circuit and diodes in every assembly step - thereby making it easier to achieve a high degree of quality control of the mixer assembly.

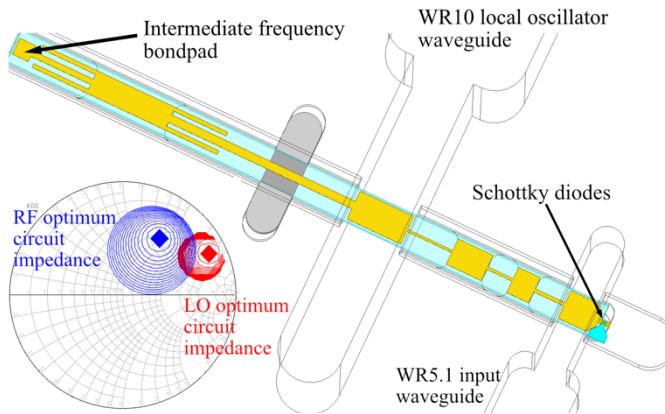

Fig. 2. Three dimensional model of the mixer implemented in ANSYS HFSS, where the anti-parallel Schottky diodes are located at the edge of the substrate. The model includes the silver epoxy glue seen in grey which is used to mount the mixer circuit. A hammerhead filter provides a high local oscillator rejection. The Smith chart presents the mixer circuit optimum impedances at 183 GHz (blue diamond) and 91.65 GHz (red diamond) in a 50 Ω system.

B. LNA Matching Network Design

The three stage InP HEMT LNA, with a minimum noise temperature of 10 K at 1 GHz, was co-designed with the mixer by introducing a matching network between the LNA MMIC input and the high impedance IF output of the mixer. This reduces the length between the mixer and the LNA thereby improving the IF standing wave ratio which has a significant impact on the receiver gain and noise flatness. By integrating the mixer and LNA a highly isolated IF environment is obtained

making the receiver more resilient to electromagnetic interference pickup improving the short-term receiver stability. A photograph of the MMIC LNA and the matching network including dc-block capacitors and LNA bias resistors are seen in Fig. 4. The mixer bondpad is seen to the left and the output 50 Ω transmission line is seen to the right.

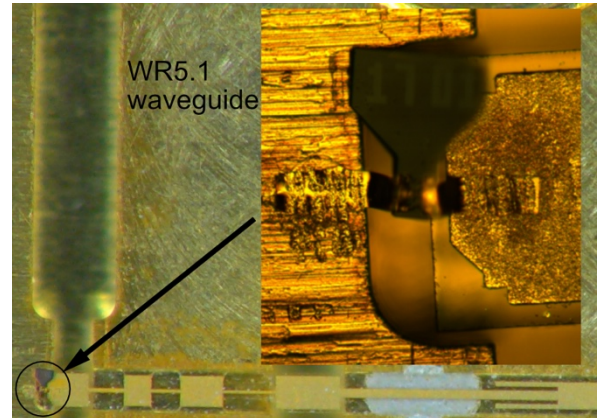

Fig. 3. Mixer circuit and suspended beamlead GaAs membrane anti-parallel Schottky diodes. The beamleads are bonded to the circuit and the mechanical platform, this minimizes the electrical length to the dc-ground.

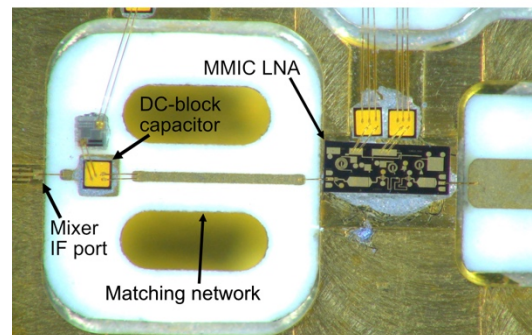

Fig. 4. Low noise amplifier (LNA) MMIC chip and matching network with dc-block capacitors and amplifier bias resistors. The mixer IF output is seen to the left of the matching network.

C. LNA Bias Circuit Board Design

The gold plated aluminium receiver split block is shown in Fig. 5 where the LNA bias protective circuit board is mounted. Feedthrough filters connect the circuit board to the LNA voltage and current controller board which is located in a compartment beneath the seen circuits. This reduces the footprint of the receiver. The dc-feedthrough filters suppress unwanted high frequency signals thereby improving the short-term stability further.

III. MEASUREMENT SETUP

The receiver noise temperature was measured using the Y-factor method in an automatic hot/cold setup. A chopper mirror switched between the cold load at room temperature and the hot load at 80 $^{\circ}\text{C}$ with a switching time of ~ 300 ms. A corrugated horn antenna was used and an in-house $\times 6$ W-band frequency multiplier acted as a LO source. The input power source was a HP 8672A synthesizer operating at 15.275 GHz with an output power of 5.5 dBm and by controlling the multiplier voltage bias the LO power into the mixer was varied.

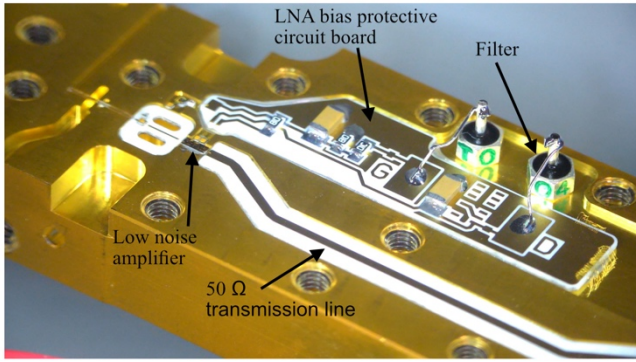

Fig. 5. Bottom receiver split-block with mounted components. The LNA bias protective circuit board is connected to the LNA controller circuit board with dc-feedthrough filters.

The short-term stability of the receiver was measured with the same Y-factor setup but instead the receiver was only observing the hot load having a temperature variation of ± 0.1 K. The non-filtered IF signal was sampled with a power meter for one hour and the sampling frequency was 1.5 kHz. The video bandwidth was 250 Hz. The stability measurement was done in a lab environment without any thermal stabilization of the receiver.

The third order LO spurious power at the RF waveguide interface was measured using a Keysight PNA-X 5242A with a WR3.4 VNA extender from VDI connected to the WR5.1 RF waveguide. The receiver was pumped with a LO power of 2.5 mW and the power of the 274.938 GHz tone was measured with a 10 Hz window swept from 274.936 GHz to 274.953 GHz.

IV. RESULTS

The receiver showed an overall noise temperature below 800 K, over the 0.3 – 13.7 GHz IF band, including horn antenna losses, at a LO power of 1 mW. A minimum noise temperature of 450 K, translating to a noise figure of 4 dB, was measured at an IF of approximately 1 GHz and a typical noise temperature of 520 K was measured over the frequency band 0.5 – 8 GHz as seen in Fig. 6. The receiver noise simulation takes thermal noise and shot-noise into account and agrees well with the measurement. The increase in noise temperature around 10 GHz is due to a standing wave between the LNA and the mixer and is a result of the matching network design which had an upper frequency limit of about 8 GHz.

The measured overlapping Allan variance is presented in Fig. 7 where the stable integration time (Allan time) is in the order of 10 s. The deviation from the 10 dB/decade theoretical line around 5 s integration time is most likely due to receiver temperature drift which is not accounted for in the theoretical case.

The third order LO spurious power is shown in Fig. 8 where the power is in the order of -60 dBm. The LO power was 2.5 mW which is 1.5 mW higher compared to the minimum receiver noise LO drive level. Some decrease in third order LO spurious power is therefore expected when operating the receiver at nominal LO power which was simulated to fall in the -70 dBm range.

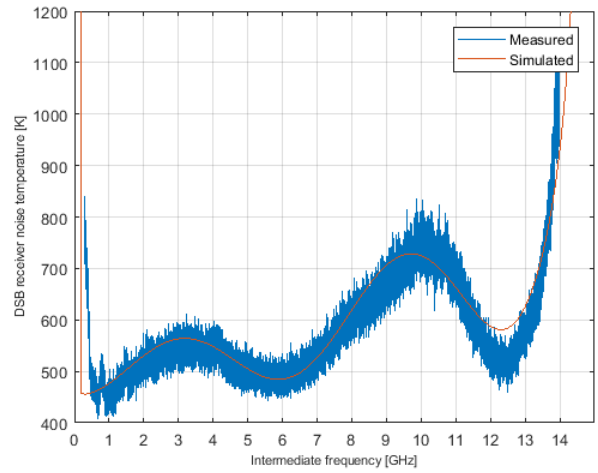

Fig. 6. Measured and simulated DSB receiver noise temperature including horn antenna losses at a LO power of 1 mW. A minimum noise temperature of 450 K was observed around 1 GHz. The simulated diode impedance was 180 Ω and the mixer conversion loss and the LNA noise temperature was 6.9 dB and 30 K respectively at 1 GHz .

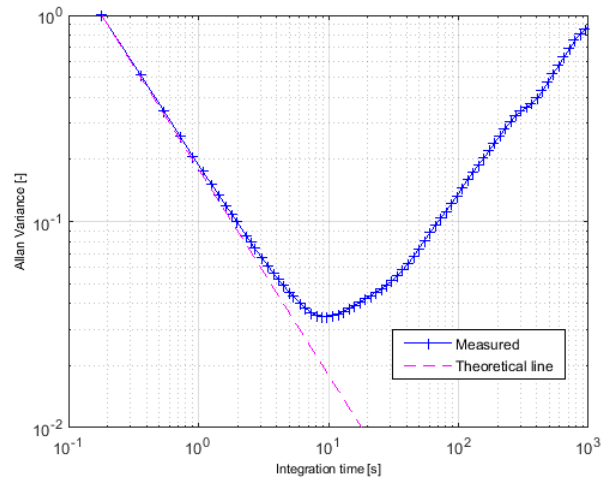

Fig. 7. Measured overlapping Allan variance compared to the theoretical case where the Allan time is in the order 10 s.

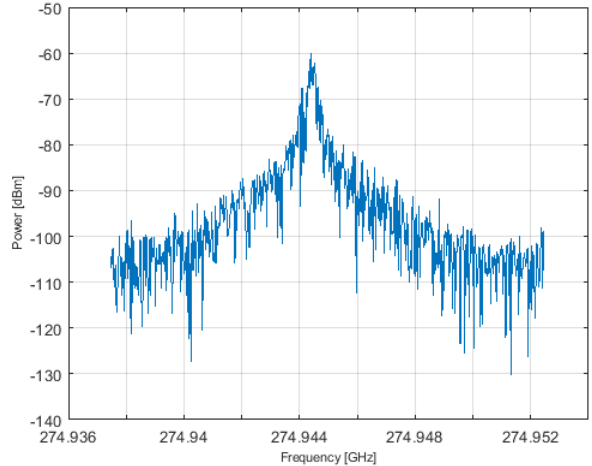

Fig. 8. Third order local oscillator spurious power generated by the antiparallel diode at the receiver input waveguide. The power is in the order of -60 dBm at a local oscillator power of 2.5 mW.

A comparison between state-of-the-art Schottky mixers and Schottky, HEMT and CMOS receivers are presented in Table 1. The measured minimum receiver noise temperature, which includes the LNA noise temperature and antenna losses is lower than reported mixer noise temperatures and in the same order as reported HEMT receiver noise temperatures.

Table 1. Comparison of different state-of-the-art Schottky mixers, Schottky receivers and HEMT receivers.

Freq. [GHz]	Technology	Noise temp. [K]	Ref.
166	InP HEMT receiver	455*	[10]
183	Schottky receiver	450	This
183	InP HEMT receiver	550**	[11]
183	InGaAs mHEMT on-wafer LNA	359	[12]
183	Schottky mixer	500	[13]
183	28 nm CMOS receiver	2610	[14]
190	Schottky mixer	550	[15]
240	Schottky mixer	490	[16]
240	InAlAs/InGaAs mHEMT receiver	1163	[17]
250	Schottky mixer	1310	[18]
330	Schottky mixer	700	[7]
340	Schottky receiver	870	[5]
340	Schottky mixer	757	[6]

*Packaged LNA noise temperature was 350 K at 183 GHz with a minimum of 275 K at 150 GHz.

**Packaged LNA noise temperature was 510 K at 183 GHz with a minimum of 370 K at 160 GHz.

V. CONCLUSION

A state-of-the-art 183 GHz Schottky receiver implementing a repeatable and robust assembly method, based on membrane integrated beamlead Schottky diodes, has been demonstrated. The simple mixer assembly enables visual inspection of the process thereby improving the reliability of the receiver. Careful package integration and co-optimization of the mixer with the IF LNA reduces losses and improves susceptibility to electromagnetic interference. The measured minimum receiver noise temperature is 450 K and the measured short-term receiver stability and third order LO spurious power is 10 s and below -60 dBm respectively. Considering the RF performance, the proposed mixer implementation and receiver assembly method makes this receiver highly suitable for space and other demanding terahertz applications.

ACKNOWLEDGMENT

This research has been carried out in the GigaHertz Centre in a project financed by VINNOVA, Chalmers, Omnisys Instruments, Low Noise Factory, Wasa Millimeter Wave, and RISE.

REFERENCES

[1] S. D'. Addio, V. Kangas, U. Klein, M. Loiselet, and G. Mason, "The microwave radiometer on-board MetOp second generation satellites," *IEEE Metro. Aero. Space.*, pp. 599–604, 2014. DOI: 10.1109/MetroAeroSpace.2014.6865995.

[2] D. D. Turner, "Improved ground-based liquid water path retrievals using a combined infrared and microwave approach," *Journal of Geophysical*

Research: Atmospheres, vol. 112, no. D15, pp. 1–15, Aug. 2007. DOI: 10.1029/2007JD008530.

[3] M. P. Caddedu, J. C. Liljegren, and D. D. Turner, "The atmospheric radiation measurement ARM program network of microwave radiometers: instrumentation, data, and retrievals," *Atmospheric Measurement Techniques.*, vol. 6, no. 9, p. 2359, Sep. 2013. DOI: 10.5194/amt-6-2359-2013.

[4] I. Mehdi, J. V. Siles, C. Lee, and E. Schlecht, "THz diode technology: Status, prospects, and applications," *Proc. IEEE*, vol. 105, no. 6, pp. 990–1007, Jun. 2017.

[5] P. Sobis, N. Wadefalk, A. Emrich, and J. Stake, "A broadband, low noise, integrated, 340 GHz Schottky diode receiver," *IEEE Microw. Compon. Lett.*, vol. 22, no. 7, pp. 366–368, Jul. 2012. DOI: 10.1109/LMWC.2012.2202280.

[6] C. Wang, Y. He, B. Lu, J. Jiang, L. Miao, X. Deng, Y. Xiong, and J. Zhang, "Robust sub-harmonic mixer at 340 GHz using intrinsic resonances of hammer-head filter and improved diode model," *J. Infrared Milli. Terahz. Wave*, vol. 38, no. 11, pp. 1397–1415, Nov. 2017. DOI: 10.1007/s10762-017-0436-4.

[7] B. Thomas, A. Maestrini, and G. Beaudin, "A low-noise fixed-tuned 300-360 GHz sub-harmonic mixer using planar Schottky diodes," *IEEE Microw. Compon. Lett.*, vol. 15, no. 12, Dec. 2005. DOI: 10.1109/LMWC.2005.859992.

[8] S. P. Rea, B. Thomas, and D. N. Matheson, "A 320-360 GHz sub-harmonically pumped image-rejection mixer for earth observation applications," in *2008 33rd Int. Conf. on Infrared, Millimeter and Terahertz Waves*, Sep. 2008. DOI: 10.1109/ICIMW.2008.4665707.

[9] A. Maestrini, L. Gatilova, J. Treuttel, F. Yang, Y. Jin, A. Cavanna, D. Moro Melgar, F. Tamazouzt, T. Vacelet, A. Féret, F. Dauplay, J.-M. Krieg, and C. Goldstein, "1200 GHz and 600 GHz Schottky receivers for JUICE-SWI," presented at the 27th International Symposium on Space Terahertz Technology, Nanjing 2016.

[10] P. Kangaslahti, L. Boon, T. Gaier, A. Tanner, M. Varonen, L. Samoska, S. Brown, B. Lambrigtsen, S. Reising, J. Tanabe, O. Montes, D. Dawson, and C. Parashare, "Low noise amplifier receivers for millimeter wave atmospheric remote sensing," in *Proc. Int. Microw. Symp.*, Jun. 2012, pp. 1-3. DOI: 10.1109/MWSYM.2012.6259468.

[11] P. Kangaslahti, D. Pukala, T. Gaier, W. Deal, X. Mei, and R. Lai, "Low noise amplifier for 180 GHz frequency band," in *2008 IEEE MTT-S Int. Microwave Symp. Dig.*, Atlanta, GA, Jun. 2008, pp. 681–684. DOI: 10.1109/MWSYM.2008.4633200.

[12] G. Moschetti, A. Leuther, H. Maßler, B. Aja, M. Rösch, M. Schlechtweg, O. Ambacher, V. Kangas, and M. Geneviève-Perichaud, "A 183 GHz metamorphic HEMT low-noise amplifier with 3.5 dB noise figure," *IEEE Microw. Compon. Lett.*, vol. 25, no. 9, Sep. 2015. DOI: 10.1109/LMWC.2015.2451355.

[13] Virginia Diodes. (2018). Mixers – VDI Model: WR4.3SHM, [Online]. Available: <https://www.vadiodes.com/en/products/mixers?id=129>

[14] A. Tang, Y. Kim, Y. Xu, G. Virbila, T. Reck and M-C F. Chang, "Evaluation of 28 nm CMOS receivers at 183 GHz for space-borne atmospheric remote sensing," *IEEE Microw. Compon. Lett.*, vol. 27, no. 1, Jan. 2017. DOI: 10.1109/LMWC.2016.2630002.

[15] RPG Radiometer Physics GmbH (2018). Subharmonic Mixer narrowband 170-210 GHz, [Online]. Available: <https://www.radiometer-physics.de/products/mmwave-and-terahertz-products/mixers/mixers-subharmonic-and-harmonic-mixers/high-performance-subharmonic-mixers/1/subharmonic-mixer-narrowband-170-210-ghz/#tabs-container-0>

[16] I. Mehdi, S. M. Marazita, D. A. Humphrey, T.-H. Lee, R. J. Dengler, J. E. Oswald, A. J. Pease, S. C. Martin, W. L. Bishop, T. W. Crowe, and P. H. Siegel, "Improved 240-GHz subharmonically pumped planar Schottky diode mixers for space-borne applications," *IEEE Trans. Microw. Theory Techn.*, vol. 46, no. 12, pp. 2036–2042, Dec. 1998. DOI: 10.1109/22.739280.

[17] T. Merkle, S. Wagner, A. Tessmann, M. Kuri, H. Massler, and A. Leuther, "Integrated 220–260 GHz radar frontend," in *2018 IEEE BiCMOS and Compound Semiconductor Integrated Circuits and Technology Symp.*, San Diego, CA, Oct., 2018, pp. 235–238. DOI: 10.1109/BCICTS.2018.8550939. DOI: 10.1109/22.739280.

[18] P. H. Siegel, R. J. Dengler, I. Mehdi, W. L. Bishop, and T. W. Crowe, "A 200 GHz planar diode subharmonically pumped waveguide mixer with state-of-the-art performance," in *1992 IEEE MTT-S Microwave Symp. Dig.*, Albuquerque, NM, Jun. 1992, pp. 595–598. DOI: 10.1109/MWSYM.1992.188052.