



Review of Technical Design and Safety Requirements for Vehicle Chargers and Their Infrastructure According to National Swedish and Harmonized

Downloaded from: <https://research.chalmers.se>, 2025-05-22 09:28 UTC

Citation for the original published paper (version of record):

Kersten, A., Rodionov, A., Kuder, M. et al (2021). Review of Technical Design and Safety Requirements for Vehicle Chargers and Their Infrastructure According to National Swedish and Harmonized European Standards. *Energies*, 14(11). <http://dx.doi.org/10.3390/en14113301>

N.B. When citing this work, cite the original published paper.

Review

Review of Technical Design and Safety Requirements for Vehicle Chargers and Their Infrastructure According to National Swedish and Harmonized European Standards

Anton Kersten ^{1,*}, Artem Rodionov ¹, Manuel Kuder ², Thomas Hammarström ¹, Anton Lesnicar ² and Torbjörn Thiringer ¹ 

¹ Department of Electrical Engineering, Chalmers University of Technology, Hörsalsvägen 11, 41258 Gothenburg, Sweden; artem@chalmers.se (A.R.); thomas.hammarstrom@chalmers.se (T.H.); torbjorn.thiringer@chalmers.se (T.T.)

² Department of Electrical Engineering, Bundeswehr University Munich, Werner-Heisenberg-Weg 39, 85579 Neubiberg, Germany; manuel.kuder@unibw.de (M.K.); a_lesnicar@yahoo.de (A.L.)

* Correspondence: kersten@chalmers.se; Tel.: +46-317721305

Abstract: Battery electric vehicles demand a wide variety of charging networks, such as charging stations and wallboxes, to be set up in the future. The high charging power (typically in the range of a couple of kW up to a couple of hundred kW) and the possibly long duration of the charging process (up to more than 24 h) put some special requirements on the electrical infrastructure of charging stations, sockets, and plugs. This paper gives an overview of the technical design requirements and considerations for vehicle charging stations, sockets, and plugs, including their infrastructure, according to the Swedish Standard 4364000, “Low-voltage electrical installations—Rules for design and erection of electrical installations”, and the corresponding harmonized European standards. In detail, the four internationally categorized charging modes are explained and the preferable charging plugs, including their two-bus communication, according to European Directives are shown. The dimensioning of the supply lines and the proper selection of the overcurrent protection device, the insulation monitor, and the residual current device are described. Furthermore, a comprehensive overview of the required safety measures, such as the application of an isolation transformer or the implementation of an overvoltage protection mechanism, and the limits for conducted electromagnetic emissions, such as low-frequency harmonics or high-frequency (150 kHz to 108 MHz) emissions, are given.

Keywords: battery chargers; battery management systems; charging modes; charging plugs; charging sockets; charging stations; design standards; electric vehicles; harmonic emissions; harmonized standard; vehicle charging; vehicle safety; voltage drop



Citation: Kersten, A.; Rodionov A.; Kuder, M.; Hammarström T.; Lesnicar A.; Thiringer, T. Review of Technical Design and Safety Requirements for Vehicle Chargers and Their Infrastructure According to National Swedish and Harmonized European Standards. *Energies* **2021**, *14*, 3301. <https://doi.org/10.3390/en14113301>

Academic Editor: Woojin Choi

Received: 30 April 2021

Accepted: 30 May 2021

Published: 4 June 2021

Publisher's Note: MDPI stays neutral with regard to jurisdictional claims in published maps and institutional affiliations.



Copyright: © 2021 by the authors. Licensee MDPI, Basel, Switzerland. This article is an open access article distributed under the terms and conditions of the Creative Commons Attribution (CC BY) license (<https://creativecommons.org/licenses/by/4.0/>).

1. Introduction

The number of deployed electric vehicles has significantly increased throughout the past few years [1,2], and vehicles' battery capacities are becoming larger, as well [3]. In the future, this trend is presumably going to continue [3,4]. Thus, the energy demand and the power requirements on the electrical grid, due to the charging of electric vehicles, are steadily rising, as well. Especially, the high charging power (typically in the range of a couple of kW up to a couple of hundred kW) and the long charging duration of the charging process (up to more than 24 h) put some special requirements on charging stations' infrastructure, including charging plugs and charging sockets. Furthermore, to implement smart charging strategies, such as sharing of the available power among several vehicles [5], electricity-price triggered charging [6], primary and secondary frequency control [7,8] capability, or utilization as a domestic energy storage system (ESS) [9], a communication between the vehicle and the charging station/socket is required. The currently available national and international regulations, as well as directives, shall help to

set harmonized design and safety requirements for charging stations, sockets, and plugs, including their infrastructure.

Despite technically feasible, not all kinds of charger topologies fulfill the necessary safety precautions according to the locally applicable standards. For example, in [10,11], a comprehensive review of various state-of-the-art integrated battery charger topologies is given. These integrated chargers aptly utilize the traction motor's phase inductances to significantly reduce the required grid filter's size, which saves space and cost. Although, most of the presented topologies (6 of 8) in [10] are non-isolated converter topologies. In contrast, an isolated converter type breaks the ground loop between a vehicle's battery and the AC grid and, thus, reduces the risk of unwanted common mode noise, which can compromise the vehicle's and the user's safety. Therefore, according to the national Swedish Standard (SS) 4364000 [12], "Low-voltage electrical installations—Rules for design and erection of electrical installations", only isolated charger types with a permanently installed transformer shall be used for vehicle charging. Based on this simple example, it can be seen that it is quite important to comply with the safety regulations described in the governing standards, despite other technical solutions seem more beneficial in terms of the system's costs and power density.

This paper gives a comprehensive but concise overview about the technical design and safety requirements of conductive charging stations and systems, including their infrastructure, for battery electric vehicles (BEV) and plug in hybrid vehicles (PHEV) according to the governing Swedish Standard 4364000, "Low-voltage electrical installations—Rules for design and erection of electrical installations", and the corresponding harmonized European and international standards. In detail, the four internationally categorized charging modes are explained and the preferable charging plugs, including their two-bus communication, according to European Directives are shown. The dimensioning of the supply lines and the proper selection of the overcurrent protection device, the insulation monitor, and the residual current device are described. Furthermore, a comprehensive overview of the required safety measures, such as the application of an isolation transformer or the implementation of an overvoltage protection mechanism, and the limits for conducted electromagnetic emissions, such as low-frequency harmonics or high-frequency (150 kHz to 108 MHz) emissions, are given.

Within the frame of this paper, all numbered European Standards carry the preceding abbreviation EN (European Norm, as literally translated from French/German) and standards issued by the International Electrotechnical Commission are abbreviated as IEC. Furthermore, harmonized standards are abbreviated by the national Swedish Standard abbreviation SS and the international standard's abbreviation, for example, SS EN, SS IEC, etc.

So far, wireless/inductive charging, as, for example, described in [13,14], is not yet covered in the SS 4364000 and, thus, is not considered within the scope of this paper.

2. Charging Modes

As described in [15], there are four different **charging modes** for BEVs and PHEVs, which are illustrated in Figure 1. In general, charging mode 1, 2 and 3 utilize an on-board charger (OBC), which is supplied by the AC mains or an AC charging station. Charging mode 4 instead employs a DC charging station, and it is often referred to as fast charging. Furthermore, charging mode 3 and charging mode 4 require a special and permanently installed electrical infrastructure, including a communication between the charging station and the vehicle. In contrast, charging mode 1 can be realized by a direct connection between a domestic power socket and the OBC without requiring any additional communication infrastructure between the mains and the vehicle. Similar to charging mode 1, charging mode 2 can utilize a domestic power socket, but some additional equipment is needed. During the charging process, independent of the charging mode, the required battery management system (BMS) shall ensure that each of the individual battery cells are evenly charged (typically, using passive balancing [16,17]) and that the maximum battery voltage limit is not exceeded. Moreover, the BMS can also request to reduce the reference current,

which is controlled by the OBC or the DC charging station, to ensure not to exceed the maximum allowable battery temperature. In the following, the individual charging modes are explained in detail.

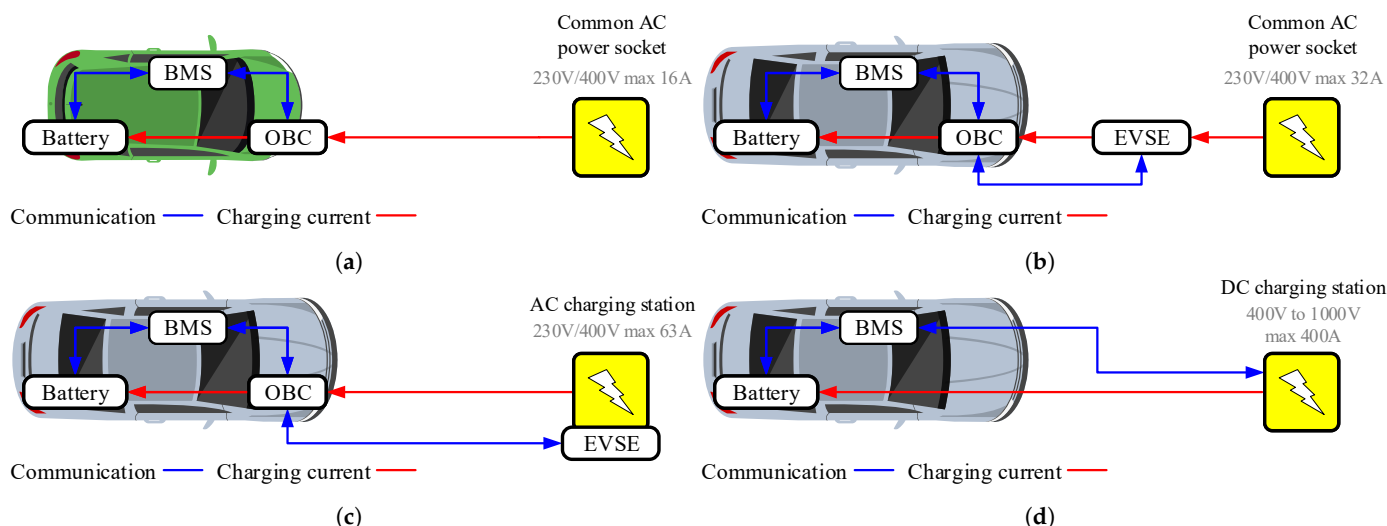

Figure 1. Illustration of the four charging modes as described in [12]. (a) Charging mode 1. (b) Charging mode 2. (c) Charging mode 3. (d) Charging mode 4.

As already mentioned, **charging mode 1** consists of a direct connection between the electric vehicle and the AC mains, 230 V/400 V with a maximum allowable current rating not exceeding 16 A. Typically, a common domestic (single-phase) AC socket, without any additional safety systems, can be used to supply the vehicle. The OBC rectifies the AC voltage to charge the battery. Unless unplugged, the lead is always live when using charging mode 1. Normally, charging mode 1 is only used for light vehicles, such as electric bikes or scooters with a low-voltage (≤ 60 V) battery system and a maximum charging power of a couple of hundred watts. In some European countries, charging mode 1 is subject to restrictions in public areas, and it is not allowed in Israel, the United Kingdom, and the United States [18]. According to [12], charging mode 1 is usually not supported for electric passenger cars.

Unlike charging mode 1, **charging mode 2** requires some additional electrical control/safety equipment, referred to as electric vehicle supply equipment (EVSE). The EVSE is placed between the OBC and the AC power socket, typically integrated in the charging cable. Via a two-wire communication bus and a control unit, the EVSE can set the reference charging current for the OBC. Additionally, the EVSE monitors the charging process. When the battery is fully charged, the EVSE disconnects the OBC from the AC mains, referred to as safety lock-out. Furthermore, the EVSE can detect hardware faults, such as a faulty cable plug connection or an external short-circuit fault. For charging mode 2, both domestic (single-phase) and industrial (three-phase) AC sockets with a current rating up to 32 A can be used. Consequently, the maximum three-phase charging power, assuming unity power factor ($\cos(\varphi) \approx 1$) [19], according to

$$P_{\text{Charging}} = 3 \cdot I_B \cdot V_{\text{Phase, rat}} \cdot \cos(\varphi) \quad , \quad (1)$$

becomes

$$P_{\text{Charging}} = 3 \times 32 \text{ A} \times 230 \text{ V} \times 1 \approx 22.1 \text{ kW} \quad . \quad (2)$$

Nonetheless, only AC sockets designated for charging should be used, since the charging process can occupy the available power capability of the grid's connection point for several hours, as listed in Table 1. Furthermore, domestic (single-phase) AC sockets can rapidly wear out when loaded over a long period with rated current [20]. Thus, charging

a vehicle from a domestic AC socket, which is not designated for charging, should be considered only as “emergency charging”.

Table 1. Charging time of a BEV with a battery capacity of about 60 kWh with respect to the charging type.

Charging Type	Power Rating [kW]	Charging Time [h]
Single-phase—10 A	2.3 kW	26.1
Single-phase—16 A	3.7 kW	16.2
Three-phase—16 A	11 kW	5.5
Three-phase—32 A	22 kW	2.7
Three-phase—63 A	44 kW	1.4
DC fast charging	50 kW	1.2
DC fast charging	120 kW	0.5

Charging mode 3 requires that the BEV or PHEV is charged via an AC charging station, which is permanently connected to the grid. The EVSE, including the control and safety functions, is directly integrated into the charging station. Normally, wall-boxes, charging columns, commercial charging points and all automatic AC charging systems (with an integrated EVSE) are considered as AC charging stations in accordance with charging mode 3. The current rating of the charging station can be up to 63 A [12]. Consequently, the maximum three-phase charging power, assuming unity power factor ($\cos(\varphi) \approx 1$) [19], according to

$$P_{\text{Charging}} = 3 \cdot I_B \cdot V_{\text{Phase, rat}} \cdot \cos(\varphi) \quad , \quad (3)$$

becomes

$$P_{\text{Charging}} = 3 \times 63 \text{ A} \times 230 \text{ V} \times 1 \approx 43.5 \text{ kW} \quad . \quad (4)$$

Since the charging power for charging mode 3 can be significantly increased in comparison to charging mode 1 and charging mode 2, specially designated AC sockets and charging plugs should be used, as further explained in Section 3. Charging mode 3 should be preferably used for home charging stations and, according to the EU directive 2014/94 [21], it should be employed at public charging stations.

Charging mode 4 is the only mode that utilizes DC current. As illustrated in Figure 1d, no OBC is required, since there is a direct connection between the charging station and the vehicle’s battery. The power electronics circuitry, which is integrated in the DC charging station, can adjust the output voltage to control the DC charging current. Typically, the output voltage can be adjusted up to 1000 V and the charging current can be up to 400 A. Thus, a charging station according to charging mode 4 can theoretically achieve a charging power of a couple of hundred kW [22]. However, the battery’s charging efficiency is significantly decreased when using such a high charging power [23]; thus, the BMS has to constrain the maximum charging power to comply with the temperature limit of the battery system. Therefore, DC charging stations for passenger vehicles are often operated with a continuous power from 40 kW to 130 kW.

3. Charging Plugs and Socket-Outlets

The high charging power, the possibly long duration of the charging process (see Table 1) put some special requirements on the electrical infrastructure, including the charging plugs and the charging sockets. Furthermore, with respect to the project IEEE 2030 [24], “Guide for Smart Grid Interoperability of Energy Technology and Information Technology Operation with the Electric Power System (EPS), End-Use Applications, and Loads”, the charging plugs and sockets should preferably comprise a communication interface and the charging infrastructure should allow for bidirectional power flow capability.

For example, domestic (single-phase) wall-mounted AC sockets or plugs according to the SS-428-08-34 [25] or the internationally harmonized IEC standard SS-IEC-60884-1 [26]

can rapidly wear out when loaded over a long time with rated current [20]. In contrast, industrial (three-phase) socket-outlets according to the SS-EN-60309-1 [27] and the SS-EN-60309-2 [28] can be fully utilized, but the current rating shall not exceed 32 A according to charging mode 2 [12]. Nonetheless, the charging process can easily occupy the full current capability of the grid's connection point for a long duration (see Table 1), while no other loads can be used. Thus, it is often reasonable to adjust/reduce the charging current accordingly or to balance the available power among all loads. However, both domestic and industrial AC sockets do not provide any communication between the vehicle's OBC and the AC socket to adjust the reference current for the charging process. Therefore, to adjust/reduce the charging current, at least some additional EVSE would be required when charging a vehicle from a domestic or industrial socket-outlet (charging mode 2). For example, Figure 2 shows a single-phase charging cable from Deltaco [29] with a Schuko and a Type 2 connector including an in-line integrated EVSE, which includes a communication interface to adjust the charging current's reference between 10 A and 16 A.



Figure 2. Single-phase charging cable with Schuko and Type 2 connector including in-line integrated EVSE to adjust the charging current reference between 10 A and 16 A from Deltaco [29].

To achieve higher charging power levels ($>>20$ kW), as desired for public charging stations, the charging plugs and sockets according to the standard series SS-EN-62196 [30–32] (harmonized European standard) shall be used, which is in accordance with the international standard series IEC-62196, “Plugs, socket-outlets, vehicle connectors and vehicle inlets—Conductive charging of electric vehicles”. The plugs and socket-outlets according to the standard series SS-EN 62196 are not only rated for high current levels, these also comprise an interface for a two-wire bus communication, referred to as vehicle to grid (V2G) communication interface in accordance with the SS-EN-ISO 15118-1 [33]. With the help of the communication interface, smart charging strategies can be easily realized. For example, the available power of a public charging station could be evenly distributed among all vehicles [5] or a vehicle is only charged if the electricity price is below a certain threshold [6]. Moreover, considering the IEEE Std 1547 [34], “IEEE Standard for Interconnection and Interoperability of Distributed Energy Resources with Associated Electric Power Systems Interfaces”, vehicles' charging infrastructure can provide also ancillary service functions for distribution or transmission system operators, such as intentional local islanding possibility [9,35] or primary and secondary frequency control capability [7,8]. The Type 2 charging plug according to the standard SS-EN-62196-2 [31] can be seen in Figure 3a. It should be used for three-phase AC charging according to charging mode 3, but it is not limited to it. The Combo 2 charging plug according to standard SS-EN-62196-3 [32] can be seen in Figure 3b. It should be used for DC charging according to charging mode 4. With respect to the harmonized European standard series EN 62196, the EU directive 2014/94 [21] states

that any public charging station should comprise at least one charging plug of Type 2 and one of type Combo 2. The combined charging socket of Type 2 and Combo 2 (CCS 2), manufactured by Khons Technology, can be seen in Figure 3c. This combined charging system (CCS) is commonly abbreviated as CCS 2 and it should be preferably used for EVs in Sweden and the European Union. As can be seen from Figure 3c, the CCS 2 socket comprises a two wire communication bus (PP and CP), a normal three-phase connection interface (L1, L2, L3, N, and PE), and a DC connection interface (DC+ and DC-). Both, the Type 2 and the Combo 2, as well as the CCS 2, charging plugs and sockets are recognized in North America under the recommended practice of the SAE J3068 [36], “Electric Vehicle Power Transfer System Using a Three-Phase Capable Coupler”.

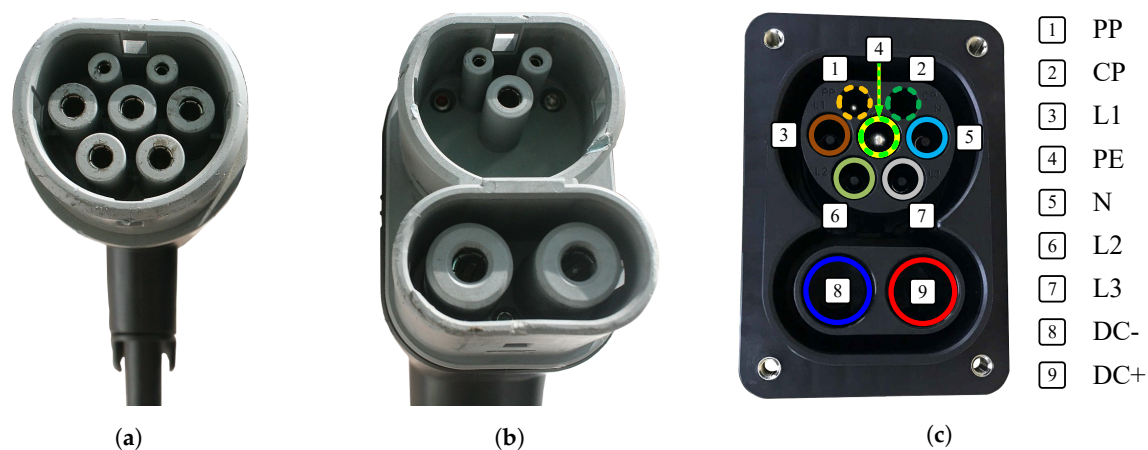

Figure 3. Charging plugs [37]: (a) Type 2 according to the SS-EN-62196-2 [31] and (b) Combo 2 according to the SS-EN-62196-3 [32]. Charging socket [38]: (c) CCS 2 socket-outlet from Khons Technology allowing for charging via a Type 2 or a Combo 2 plug according to the SS-EN-62196-3 [32].

Another (globally) popular charging system is the CHAdeMO system [39,40] (for DC charging), which stands for “CHArge de MOve”. However, especially due the EU directive 2014/94 [21], the CCS 2 is becoming dominant in Europe in comparison to the CHAdeMO system.

Furthermore, while using charging mode 3 or charging mode 4, an electrical or mechanical mechanism, sometimes referred to as latch-locking, should be used to lock the charging plug [12]. This measure should ensure a low electrical contact resistance.

4. Overcurrent Protection and Cable Dimensioning

The approximated time durations to fully charge a BEV with a nominal battery capacity of about 60 kWh with respect to different charging types are given in Table 1. For example, when using single-phase charging with a maximum current rating of about 10 A or 16 A, the required charging time can be up to 26.1 h or 16.2 h, respectively. Thus, when loading the electrical mains for such a long time with the rated current, it is important to properly dimension the electrical infrastructure, such as plugs and socket-outlets, including the cables and the overcurrent protection. Therefore, this section gives a short description on how to dimension the cables’ conductor size and how to select the corresponding overcurrent protection device for a charging application.

In general, according to [12], any power-socket designated for charging should be placed as close as possible to the vehicle’s parking spot. Thereby, the voltage drop (losses) along the cable should be kept as small as possible and the proper functioning of any overcurrent protection device should be ensured.

4.1. Selection of Overcurrent Protection Device

When designing the electrical installation for a charging station/socket, it is reasonable to start with the selection of the overcurrent protection device. As described in [12], any over-current protection device should satisfy the following relation

$$I_B \leq I_n \leq I_z \quad , \quad (5)$$

with I_B being the rated current of the load circuitry and I_n being the nominal current of the selected circuit breaker or fuse. The conductors' nominal current capability I_z can be described according to

$$I_z = I_{z,0} \cdot k_T \cdot k_M \quad , \quad (6)$$

with $I_{z,0}$ being the conductors' current capability for a certain cross-sectional area under consideration of the method of installation. The coefficients k_T (temperature) and k_M (grouping) should be used to correct the conductors' current rating relative to the ambient temperature and the number of touching multi-core cables or groups of single-core cables, respectively. Moreover, as further described in [12], the overcurrent protection device should also satisfy the relation

$$I_2 \leq 1.45 \cdot I_z \quad , \quad (7)$$

with I_2 being the current value that ensures a proper functioning of the overcurrent protection device.

For example, a typical tripping characteristic of a type C miniature circuit breaker, according to the SS-EN 60898-1 [41], with a nominal current rating of I_n can be seen in Figure 4.

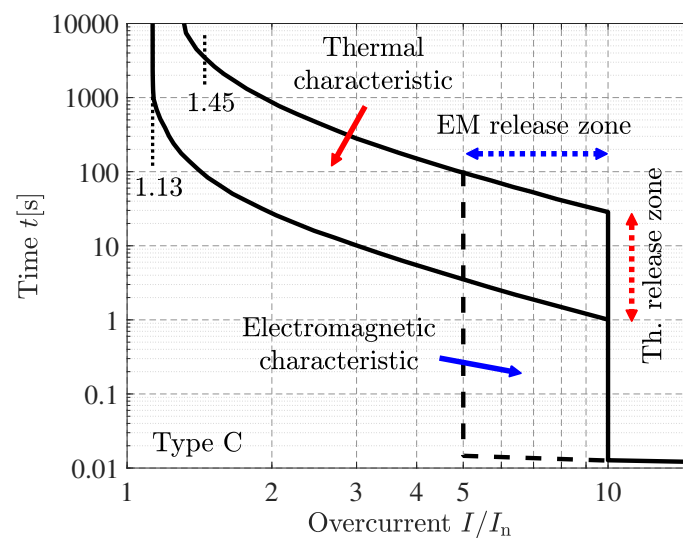

Figure 4. Tripping characteristic of type C miniature circuit breaker: time till trip versus current as multiple of nominal current I/I_n .

Typically, a miniature circuit breaker comprises two tripping mechanisms. A thermal and an electromagnetic mechanism are used for the protection against overcurrents or short-circuit faults, respectively. At the left-hand side of the thermal release zone in Figure 4 no overcurrent fault would be detected as long as the relative overcurrent I/I_n is less than 1.13. Nonetheless, if the relative overcurrent I/I_n exceeds 1.45, an overcurrent fault is certainly detected by the thermal tripping mechanism; thus, the condition in (7) would always be satisfied as long the current capability I_z was chosen in accordance with (5). In comparison to the thermal release zone, the electromagnetic release zone describes the protection against short-circuit faults. As can be seen, a short circuit fault can be detected, if the relative overcurrent I/I_n is higher than 5 and lower than 10 (EM release zone of type C circuit breaker). Moreover, for high short circuit currents ($I/I_n \geq 10$),

the time till tripping is almost instantaneously. The boundaries of the EM release zone are dependent on the circuit breaker's characteristic (e.g., A, B, C, etc.) and should be chosen in accordance with the load. For instance, the high starting current of a electric line-start machine [42] shall not be misinterpreted as a short-circuit fault; thus, the lower boundary of the EM release should be accordingly chosen (typically, type C). For a charging application, the inrush currents can be easily limited by pre-charging resistors or soft starters. Thus, for charging applications, it is often sufficient to select a type B circuit breaker (EM release zone: $3 \leq I/I_n \leq 5$).

4.2. Placement of Overcurrent Protection Device

Normally, parallel loads can be operated at the same power socket as long as these are only consuming electrical energy. However, if power-consuming and power-generating devices are connected in parallel at the same connection point, the proper functioning of its closest over-current protection device might not be ensured anymore. Despite vehicle charging stations/sockets are mainly considered as power-consumers, these can also be utilized as energy-storages. In this way, a fleet of electric vehicles can possibly inject active power into the power-system to assist the primary or secondary frequency control functionality [7,8], and, thereby, the power-system's frequency can be maintained. Furthermore, a vehicle's battery could also be used as a domestic energy storage [9]. Therefore, as described in [12], the grouping factor k_M in (5) shall be equal to one for any supply line feeding an individual charging point. This means that each designated charging point/socket must be individually protected against overcurrent and short circuit faults. In contrast, the grouping factor k_M for the main line, supplying the distribution network of a charging station, can be reduced if a proper load control management system is used [12].

4.3. Permissible Voltage Drop along the Supply Line

According to [12], the maximum permissible voltage drop along the power supply line, from the mains distribution to the load, corresponds to 5%. As described in [12], the relative voltage drop $V_{\text{Drop},\%}$ along the supply line can be calculated according to

$$V_{\text{Drop},\%} = 100\% \cdot \frac{V_{\text{Drop}}}{V_{\text{Phase, rat}}} \quad (8)$$

with V_{Drop} being the absolute voltage drop at rated load operation, and $V_{\text{Phase, rat}}$ being the nominal phase voltage of the mains, corresponding to 230 V in Sweden [43]. Further, the absolute voltage at rated load, as described in [12], can be calculated according to

$$V_{\text{Drop}} = b \left[\rho_T \frac{L}{A} \cos(\varphi) + \lambda L \sin(\varphi) \right] I_B \quad (9)$$

as further explained in the following. As before mentioned, the rated load operation of the supply line should be considered when conducting the line's rated load current I_B [A] with the corresponding power factor angle φ [rad s⁻¹]. For vehicle charging applications, it can be assumed that modern power electronic converters can achieve a power factor close to unity [44,45]. The dimensionless coefficient b corresponds to 2 or 1 for a single or three-phase system, respectively. The variables L [m] and A [mm²] describe the conductors' length and their cross-sectional area, respectively. The relative resistivity ρ_T [Ω mm² m⁻¹] of the supply line's conductors is dependent on the operating temperature T [°C] and its material, such as copper or aluminum, which can be described as

$$\rho_T = \rho_0 [1 + \alpha(T - T_0)] \quad (10)$$

For example, the relative resistivity of copper corresponds to $\rho_0 = 0.0168 \Omega$ mm² m⁻¹ at $T_0 = 20$ °C with its correction factor $\alpha = 0.00404 \text{ K}^{-1}$. If the relative reactance λ [Ω m⁻¹]

is not known, it can be assumed to be about $0.08 \text{ m}\Omega \text{ m}^{-1}$ according to [12]. For example, Table 2 lists the maximum permissible cable lengths relative to the conductors' cross-sectional area and the current rating (single-phase or three-phase) under consideration of a maximum voltage drop $V_{\text{Drop},\%}$ of 5%.

Table 2. Maximum supply line length according to (9) with respect to a permissible voltage drop of $V_{\text{Drop},\%} = 5\%$.

Charging Type ^{a,b}	$A = 2.5 \text{ mm}^2$	$A = 4 \text{ mm}^2$	$A = 10 \text{ mm}^2$
Single-phase—16 A	46.9 m	75.3 m	187.4 m
Single-phase—32 A	—	—	93.7 m
Three-phase—32 A	—	—	187.4 m
Three-phase—63 A	—	—	95.2 m

^a An operating temperature of $T = 55^\circ\text{C}$ is assumed. ^b A power factor of $\cos(\varphi) \approx 1$ is assumed.

5. Protection against Electric Shock

This section gives a brief overview about the required safety measures according to [12] against an electric shock due to an indirect contact.

5.1. Residual Current Device

In a common TN (terre-neutre) earthing-system, the electrical infrastructure to supply any kind of charging system/station should be realized as a TN-S earthing-system [12]. To reduce the risk of any harm for the user of the charging station in case of an electrical insulation fault (protection against indirect contact), a residual current device (RCD) with a maximum residual current rating of 30 mA should be implemented according to [12]. In general, there are different types of RCDs, type AC, type A, type F, type B (type B+). So, the question arises, which RCD type to choose for the electrical infrastructure of a charging station/socket?

To answer this question, the different RCD detection features must be understood first. The illustrated pictograms in Figure 5 can be usually found on different RCD types, representing different features, which can be summarized as follows:

- Detection of sinusoidal residual AC currents of 50 Hz.
- Detection of pulsating residual DC currents.
- Detection of smooth residual DC currents.
- Detection of residual currents composed of multiple frequencies from 50 Hz up to 1 kHz.
- Detection of residual currents composed of multiple frequencies from 50 Hz up to 20 kHz.

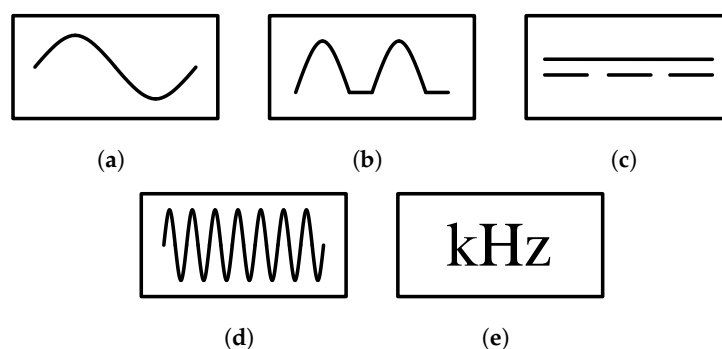

Figure 5. RCD features: (a) Detection of sinusoidal residual AC currents of 50 Hz. (b) Detection of pulsating residual DC currents. (c) Detection of smooth residual DC currents. (d) Detection of residual currents composed of multiple frequencies from 50 Hz up to 1 kHz. (e) Detection of residual currents composed of multiple frequencies from 50 Hz up to 20 kHz.

The simplest of all RCD types is type AC, which can be used to detect only residual sinusoidal AC currents (Figure 5a). This type can only be used for electrical loads, and it is rarely used anymore, since it is not suitable for any kind of electronic loads, such as diode rectifiers and active rectifiers. Thus, type AC cannot be used for any kind of charging stations. In comparison to type AC, a type A RCD can additionally handle residual pulsating DC currents (Figure 5b), and it is the most used RCD type, commonly used for domestic installations. However, the proper function of a type A RCD is ensured as long the pure DC component of the fault current does not exceed 6 mA, because the magnetic core of the RCD could saturate otherwise. Similar to type AC, a type F RCD can detect residual sinusoidal and pulsating DC currents, but in addition it can cope with residual currents that are composed of multiple frequencies up to 1 kHz (Figure 5d). The proper function of a type F RCD is ensured as long the pure DC component of the residual fault current does not exceed 10 mA. RCD type B is the only type that can handle in addition to the features of all other types also smooth residual DC currents (Figure 5c). Such residual DC currents can be caused by a fault in the intermediate DC link circuit of the power electronics circuitry. The RCD Type B+ is an enhancement of the original type B, since it can detect in addition residual currents composed of multiple frequencies from 50 Hz up to 20 kHz (Figure 5e).

Consequently, it can be concluded that a type A or a type F RCD can theoretically be used for charging stations, but it must be ensured that the DC component of the residual current does not exceed the saturation threshold current of the corresponding RCD type (6 mA for type A and 10 mA for type F). Since the RCD type B/B+ is the only one that can also cope with smooth residual DC currents, it should be preferably used for any kind of charging station. As already mentioned, a type AC RCD cannot be used, since it can only detect sinusoidal residual AC currents.

5.2. Insulation Monitor

In an IT (isolé-terre) network, the electrical distribution system shall have no connection to earth at all, or it shall have only a high-impedance connection. Usually, an RCD in an IT network does not trip after the first earth-fault. Thus, in addition to an RCD, an insulation monitor is required for an IT network. According to the recommendations in [12], the insulation monitor shall have the following characteristics for a charging station/socket:

- **Warning:** If the insulation resistance has dropped below $300 \Omega V^{-1}$, an optical and/or acoustical warning signal shall be activated. An ongoing charging process can be completed, but no new charging process shall be started.
- **Alarm:** If the insulation resistance has dropped below $100 \Omega V^{-1}$, an optical and/or acoustical warning signal shall be activated and within 10 s any ongoing charging process shall be stopped.

Furthermore, an insulation fault locator in compliance with the SS-EN 61557-9 [46] shall be used to identify the faulty electric circuit as fast as possible.

6. Further Safety Requirements

As described in [12], the electrical and electronic circuitry of a charging station/socket shall be protected by the housing/enclosure against climate conditions and intrusion of objects, which can be summarized as follows:

- **Protection against intrusion, dust, accidental contact and water:** The enclosure of an outside located charging station/socket shall fulfill at least the requirements of IP code 43 according to the SS-EN 60529 [47]. IP code 43 means that the housing protects the electrical and electronic circuitry against intrusion of objects with a larger diameter of 1 mm and spraying water.
- **Protection against external mechanical impacts:** The enclosure of a charging station/socket shall protect the electrical and electronic circuitry against external mechanical impacts. Therefore, the enclosure shall fulfill at least the requirements of IK code 07 according to the SS-EN 62262 [48]. IK code 07 means that the housing protects

the electrical and electronic circuitry against external mechanical impacts with an impact energy of up to 2 Nm.

Furthermore, according to [12], any kind of charging station/socket or system shall fulfill the following electrical safety precautions:

- **Galvanic isolation:** To avoid unwanted common mode currents, a galvanic isolation between the mains and the vehicle is required. Therefore, the vehicle's battery shall be supplied via a permanently installed transformer in accordance with the SS-EN 61558-2-4 [49].
- **Protection against lightning strikes and transient overvoltages:** To protect the electrical and electronic circuitry from any kind of unwanted overvoltages, a surge protection device type 2 according to the SS-EN 61643-11 [50] shall be implemented.
- **Emergency stop:** When an emergency stop is required, the entire load current shall be interrupted and all live conductors, including the neutral conductor, shall be disconnected via an emergency stop button.

7. Limits for Current Harmonics and Conducted Electromagnetic Emissions

To generate the desired output voltage waveforms, the power electronic converters of charging stations or OBCs typically utilize various pulse width modulation (PWM) techniques. However, a PWM waveform contains an infinite series of voltage harmonics, which can cause current harmonics or electromagnetic interference (EMI) problems.

This section gives a brief overview about the recommended limits for current harmonics and conducted electromagnetic emissions (EME), applicable for charging stations and OBCs.

7.1. Harmonic Current Emissions

In general, there are no strict regulations about the limits for harmonic current emissions (current harmonics or current THD) of grid-tied power electronic devices, such as on-board chargers or charging stations. Nonetheless, as described in [51,52], harmonic currents can cause a local fluctuation and distortion of the power system's voltage level. For example, increased voltage levels (>230 V) could lead to damages of electrical loads and equipment, whereas lower voltage levels (<230 V) typically lead to increased ohmic losses (when considering constant power loads). Furthermore, harmonic currents can cause flicker of lighting. Hence, as described in the SS-EN-50160 [43], "Voltage characteristics of electricity supplied by public distribution systems", the power system's supply voltage should be maintained at about 230 V (50 Hz), and only small voltage deviations can be tolerated. Therefore, any kind of harmonic currents shall be kept as small as possible. The IEEE Standard 519 [53], "Standard for Harmonic Control in Electric Power Systems", gives recommendations about the permissible magnitude of harmonic current components (up to the 50th component) and the total demand distortion (TDD) relative to the maximum demand current I_L and the short circuit capacity I_{SC} . For example, Table 3 shows the current distortion limits for systems rated 120 V through 69 kV, relevant for charging stations and OBCs.

To understand the ratio of the short circuit capacity I_{SC} and the maximum load demand current I_L better, Figure 6 gives a schematic illustration about the charging of a vehicle via an OBC. At the point of common coupling (PCC), an OBC is connected to the power system, charging the vehicle's battery with a maximum (demand) load current I_L . At the PCC, the grid can be characterized by the loop impedance Z_{Grid} , which is often referred to as Thévenin impedance. The size of the loop impedance Z_{Grid} characterizes the PCC's current harmonic susceptibility. For example, a strong grid has a low loop impedance; thus, the current harmonics have a reduced impact on the PCC's voltage deviation/distortion.

Table 3. Current distortion limits for systems rated 120 V through 69 kV according to the IEEE Std 519 [53].

Maximum Harmonic Current Distortion in Percent of I_L						
Individual Harmonic Order (Odd Harmonics) ^{a,b}						
I_{SC}/I_L	$3 \leq h \leq 11$	$11 \leq h \leq 17$	$17 \leq h \leq 23$	$23 \leq h \leq 35$	$35 \leq h \leq 50$	TDD
<20 ^c	4.0	2.0	1.5	0.6	0.3	5.0
$20 < 50$	7.0	3.5	2.5	1.0	0.5	8.0
$50 < 100$	10.0	4.5	4.0	1.5	0.7	12.0
$100 < 1000$	12.0	5.5	5.0	2.0	1.0	15.0
>1000	15.0	7.0	6.0	2.5	1.4	20.0

^a Even harmonics are limited to 25% of the odd harmonic limits above. ^b Current harmonics that result in a DC offset, e.g., half-wave symmetry, are not allowed. ^c All power generation equipment is limited to these values of current distortion, regardless of actual I_{SC}/I_L , where I_{SC} = maximum short-circuit current at PCC, I_L = maximum demand load current (fundamental frequency component) at the PCC under normal load operating conditions.

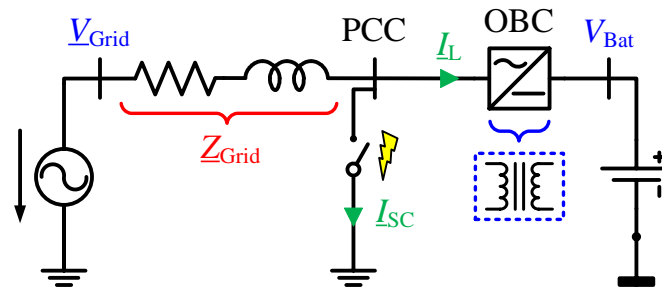
**Figure 6.** Illustration of the short-circuit capacity of the AC grid at the PCC when operating an OBC.

In practice, the loop impedance is often expressed in terms of the short circuit capacity I_{SC} , which corresponds to the theoretical current at the PCC in case of a short circuit fault, which can be estimated according to

$$I_{SC} = \frac{V_{Grid}}{Z_{Grid}} \quad (11)$$

As given in [53], the value of the TDD is defined as “The ratio of the root mean square of the harmonic content, considering harmonic components up to the 50th order and specifically excluding interharmonics, expressed as a percent of the maximum demand current”, which can be mathematically written as follows

$$TDD = 100\% \cdot \frac{1}{I_L} \sqrt{\sum_{h=3}^{50} I_h^2} \quad (12)$$

In contrast, according to [53], the value of the THD is defined as “The ratio of the root mean square of the harmonic content, considering harmonic components up to the 50th order and specifically excluding interharmonics, expressed as a percent of the fundamental current”, which should not be misinterpreted as the TDD. It should be noted that the THD is always lower than the (THD < TDD), except at the maximum demanded load current (THD = TDD).

As can be seen in Table 3, depending on the ratio I_{SC}/I_L , the maximum allowable TDD can vary between 5% and 20%. This is also valid for any kind of vehicle charging application. However, as described in footnote c of Table 3, the TDD must be limited to 5%, and the harmonic magnitudes must be limited to the values given in the first row ($I_{SC}/I_L < 20$), if the charging station or OBC is also intended to be used for bidirectional power flow.

7.2. Conducted Electromagnetic Emissions

To ensure the proper functioning of the charging infrastructure and the vehicles' on-board devices, unwanted EMI problems should be avoided. Therefore, potential sources of EMEs should be identified and mitigated during an early stage of the system's design process before the application of filters, shielding, and the like.

The Comité International Spécial des Perturbations Radioélectriques (CISPR; English: International Special Committee on Radio Interference) has issued several standards about measurement procedures of EME and the classification of various kind of electrical products relative to their EME levels. During the design process of a charging station or an OBC, it is often reasonable to focus on the conducted emissions on power cables [54,55], since these are related to the radiated emissions [56]. Depending on the charging modes described in Section 2, different CISPR standards are applicable [57]. For example, according to the CISPR 14-1 [58], "Electromagnetic compatibility—Requirements for household appliances, electric tools and similar apparatus—Part 1: Emission", the conducted emissions on the AC supply lines of the OBC should be considered when using charging mode 1 to charging mode 3. In contrast, for DC charging stations (charging mode 4), CISPR 25 [59], "Vehicles, boats and internal combustion engines—Radio disturbance characteristics—Limits and methods of measurement for the protection of on-board receivers", applies; thus, the conducted emissions on the battery's DC link rails should be limited. Both, the CISPR 14-1 and the CISPR 25, are applied in Sweden under its translated versions SS-EN 55014-1 [60] and SS-EN 55025 [61], respectively.

Since the power rating of a DC charging station is typically larger than the power rating of an OBC, charging mode 4 represents the greatest challenge regarding the limitations of EME levels [62]. To measure the conducted emissions on the DC link rails according to the SS-EN 55025 [61], two line impedance stabilization networks (LISNs) are required. A LISN mainly consist of an LC-filter, which shall couple the high-frequency noise (DM and CM components) into the measurement equipment (typically a spectrum analyzer). The low-frequency components shall not be affected by the LISNs. As depicted in Figure 7, the two LISNs must be inserted into the positive and the negative DC link rail between the battery and the power electronics converter of the charging station.

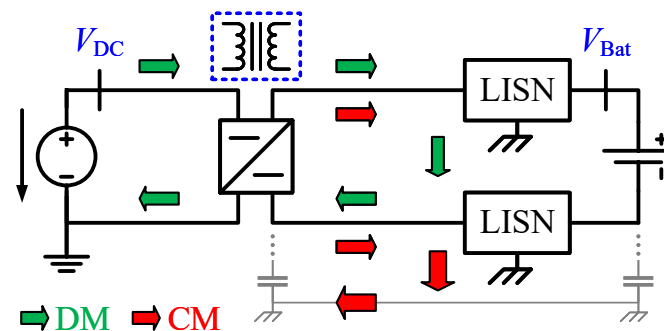

Figure 7. Illustration of the conducted emission measurement for a charging station including the CM and DM paths.

According to the SS-EN 55025 [61], the test-bench used for the measurements shall be in compliance with the CISPR series 16 [63], "Specification for radio disturbance and immunity measuring apparatus and methods". For example, as shown in [64], the surface of the test-bench shall be covered by a copper sheet (ground plate), spacers shall be used to have a separation of 5 cm to the ground plate and, further, a certain distance must be kept between the LISNs and the power electronics circuitry. The measurement of conducted emissions according to the SS-EN 55025 [61] is a typical pre-compliance test used for individual components, such as the power electronics converter of a charging station. The conducted emission levels are typically quantified in dB μ V within the frequency range from 150 kHz to 108 MHz. The limits for broadband conducted disturbances on power input terminals according to the SS-EN 55025 [61] are given in Table 4.

Table 4. Limits for broadband conducted disturbances on power input terminals according to the SS-EN 55025 [61].

Service/ Band	Frequency [MHz]	Levels [dB μ V]									
		Class 1		Class 2		Class 3		Class 4		Class 5	
		Peak	Quasi-Peak	Peak	Quasi-Peak	Peak	Quasi-Peak	Peak	Quasi-Peak	Peak	Quasi-Peak
LW ^a –AM ^b	0.15–0.3	113	100	103	90	93	80	83	70	73	60
MW ^c –AM	0.53–2.0	95	82	87	74	79	66	71	58	63	50
SW ^d –AM	5.9–6.2	77	64	71	58	65	52	59	46	53	40
VHF ^e –FM ^f	30–54	77	64	71	58	65	52	59	46	53	40
VHF–FM	70–108	61	48	55	42	49	36	43	30	37	24

^a Long wave; ^b Amplitude modulation; ^c Medium wave; ^d Short wave; ^e Very high frequency; ^f Frequency modulation.

8. Conclusions

This paper has given a comprehensive but concise overview about the technical design and safety requirements of conductive charging stations and systems, including their infrastructure, for BEVs and PHEVs according to the governing Swedish and the corresponding harmonized international and European standards. Conclusively, the main topics of the paper and the most important regulations can be shortly summarized as follows.

The four internationally categorized charging modes and the most common charging plugs and sockets have been described. To implement smart charging strategies, it is necessary that the charging infrastructure comprises a communication bus between the vehicle and the charging station. According to current European directives, any public charging station shall provide at least the charging possibility via a Type 2 and a Combo 2 plug, utilizing charging mode 3 and charging mode 4, respectively. Charging via other plugs, such as the CHAdeMO charging plug, can be publicly offered, as well, although it is not required.

Furthermore, the required overcurrent protection for charging sockets under consideration of the maximum permissible voltage drop of 5% has been described. Vehicles shall only be charged at designated charging sockets, which shall be placed as close as possible to the vehicle. Each charging socket must be individually fused, which guarantees the proper function of the fuse even when feeding energy back to the mains.

With respect to the user's safety, different required features have been described. Each charging point shall be protected by an RCD. Preferably, an RCD of type B or B+ shall be used, whereas type AC shall not be used at all. Additionally, to achieve galvanic isolation, the vehicle shall be supplied over a permanently installed transformer.

Last but not least, the maximum permissible content of harmonic and electromagnetic emissions have been described. Depending on the short circuit capacity of the charging station or socket, the maximum permissible current TDD can be up to 20%. Nonetheless, when feeding energy back from the vehicle's battery to the mains, the maximum permissible current TDD shall not exceed 5%. This aspect is quite important when designing and sizing the power electronics circuitry, including its passive components, for a charging station or an OBC.

Author Contributions: Conceptualization, A.K., A.R., M.K., T.H. and A.L.; methodology, A.K., A.R., M.K., T.H. and A.L.; software, A.K., A.R., M.K., T.H. and A.L.; validation, A.K., A.R., M.K., T.H. and A.L.; formal analysis, A.K., A.R., M.K., T.H. and A.L.; investigation, A.K., A.R., M.K., T.H. and A.L.; resources, A.K., A.R., M.K., T.H. and A.L.; data curation, A.K., A.R., M.K., T.H. and A.L.; writing—original draft preparation, A.K., A.R., M.K., T.H. and A.L.; writing—review and editing, A.K., A.R., M.K., T.H. and A.L.; visualization, A.K., A.R., M.K., T.H. and A.L.; supervision, T.T.; project administration, T.T.; funding acquisition, T.T. All authors have read and agreed to the published version of the manuscript.

Funding: The authors would like to thank the Swedish Energy Agency (Energimyndigheten) for the provided financial support.

Conflicts of Interest: The funders had no role in the design of the study; in the collection, analyses, or interpretation of data; in the writing of the manuscript, or in the decision to publish the results.

References

1. Palmer, K.; Tate, J.E.; Wadud, Z.; Nellthorp, J. Total cost of ownership and market share for hybrid and electric vehicles in the UK, US and Japan. *Appl. Energy* **2018**, *209*, 108–119. [[CrossRef](#)]
2. Rietmann, N.; Hügler, B.; Lieven, T. Forecasting the trajectory of electric vehicle sales and the consequences for worldwide CO₂ emissions. *J. Clean. Prod.* **2020**, *261*, 121038. [[CrossRef](#)]
3. Varga, B.O.; Sagoian, A.; Mariasiu, F. Prediction of Electric Vehicle Range: A Comprehensive Review of Current Issues and Challenges. *Energies* **2019**, *12*, 946. [[CrossRef](#)]
4. Morrissey, P.; Weldon, P.; O'Mahony, M. Future standard and fast charging infrastructure planning: An analysis of electric vehicle charging behaviour. *Energy Policy* **2016**, *89*, 257–270. [[CrossRef](#)]
5. You, P.; Yang, Z.; Chow, M.; Sun, Y. Optimal Cooperative Charging Strategy for a Smart Charging Station of Electric Vehicles. *IEEE Trans. Power Syst.* **2016**, *31*, 2946–2956. [[CrossRef](#)]
6. Nour, M.; Said, S.M.; Ali, A.; Farkas, C. Smart charging of electric vehicles according to electricity price. In Proceedings of the 2019 International Conference on Innovative Trends in Computer Engineering (ITCE), Aswan, Egypt, 2–4 February 2019; pp. 432–437.
7. Hernández, J.C.; Sanchez-Sutil, F.; Vidal, P.; Rus-Casas, C. Primary frequency control and dynamic grid support for vehicle-to-grid in transmission systems. *Int. J. Electr. Power Energy Syst.* **2018**, *100*, 152–166. [[CrossRef](#)]
8. Janjic, A.; Velimirovic, L.; Stankovic, M.; Petrusic, A. Commercial electric vehicle fleet scheduling for secondary frequency control. *Electr. Power Syst. Res.* **2017**, *147*, 31–41. [[CrossRef](#)]
9. Lazzeroni, P.; Olivero, S.; Repetto, M.; Stirano, F.; Vallet, M. Optimal battery management for vehicle-to-home and vehicle-to-grid operations in a residential case study. *Energy* **2019**, *175*, 704–721. [[CrossRef](#)]
10. Haghbin, S.; Lundmark, S.; Alakula, M.; Carlson, O. Grid-Connected Integrated Battery Chargers in Vehicle Applications: Review and New Solution. *IEEE Trans. Ind. Electron.* **2013**, *60*, 459–473. [[CrossRef](#)]
11. Rivera, S.; Kouro, S.; Vazquez, S.; Goetz, S.M.; Lizana, R.; Romero-Cadaval, E. Electric Vehicle Charging Infrastructure—From Grid to Battery. *IEEE Ind. Electron. Mag.* **2021**. [[CrossRef](#)]
12. SS 4364000. *Low-Voltage Electrical Installations—Rules for Design and Erection of Electrical Installations*, 3rd ed.; SEK Svensk Elstandard: Kista, Sweden, 2017.
13. Panchal, C.; Stegen, S.; Lu, J. Review of static and dynamic wireless electric vehicle charging system. *Eng. Sci. Technol. Int. J.* **2018**, *21*, 922–937. [[CrossRef](#)]
14. Pehrman, D.; Liu, Y. Design and Stray Field Evaluation of Inductive Power Transfer in Electric Vehicle Charging. In Proceedings of the 2019 Fourteenth International Conference on Ecological Vehicles and Renewable Energies (EVER), Monte-Carlo, Monaco, 8–10 May 2019; pp. 1–6. [[CrossRef](#)]
15. SS-EN 61851-1. *Electric Vehicle Conductive Charging System—Part 1: General Requirements*, 2nd ed.; SEK Svensk Elstandard: Kista, Sweden, 2011.
16. Kersten, A.; Kuder, M.; Thiringer, T. Hybrid Output Voltage Modulation (PWM-FSHE) for a Modular Battery System Based on a Cascaded H-Bridge Inverter for Electric Vehicles Reducing Drivetrain Losses and Current Ripple. *Energies* **2021**, *14*, 1424. [[CrossRef](#)]
17. Vitols, K. Efficiency of LiFePO₄ battery and charger with passive balancing. In Proceedings of the 2015 IEEE 3rd Workshop on Advances in Information, Electronic and Electrical Engineering (AIEEE), Riga, Latvia, 13–14 November 2015; pp. 1–4.
18. The 4 Electric Vehicle Charging Modes | DazeTechnology. Available online: <https://www.dazetechnology.com/charging-modes-for-ev/> (accessed on 7 March 2021).
19. Hartmann, M.; Friedli, T.; Kolar, J.W. Three-phase unity power factor mains interfaces of high power EV battery charging systems. In Proceedings of the Power Electronics for Charging Electric Vehicles ECPE Workshop, Valencia, Spain, 21–22 March 2011; pp. 21–22.
20. Meine Wallbox: Warum man nicht einfach an einer Steckdose laden kann. Available online: <https://www.eon.de/frag-eon/themen/e-mobility/article/meine-wallbox-teil-1-oder-kann-man-nicht-einfach-an-der-stec/> (accessed on 21 May 2021).
21. Directive, EU. 94/EU of the European Parliament and of the Council of 22 October 2014 on the deployment of alternative fuels infrastructure. *Off. J. Eur. Union L* **2014**, *307*, 1–20.
22. Haghbin, S. Design of a 300 kW Compact and Efficient Fast Charger Station Utilizing High-Power SiC Modules and Nanocrystalline Magnetic Materials. In Proceedings of the 2018 20th European Conference on Power Electronics and Applications (EPE'18 ECCE Europe), Riga, Latvia, 17–21 September 2018; pp. 1–7.
23. Keyser, M.; Pesaran, A.; Li, Q.; Santhanagopalan, S.; Smith, K.; Wood, E.; Ahmed, S.; Bloom, I.; Dufek, E.; Shirk, M.; et al. Enabling fast charging—Battery thermal considerations. *J. Power Sources* **2017**, *367*, 228–236. [[CrossRef](#)]
24. IEEE Std 2030. *IEEE Guide for Smart Grid Interoperability of Energy Technology and Information Technology Operation with the Electric Power System (EPS), End-Use Applications, and Loads*, 2011th ed.; IEEE: Piscataway, NJ, USA, 2011.
25. SS 428 08 34. *Plugs and Socket-Outlets for Household and Similar Purposes—Particular Requirements for Plugs and Socket-Outlets Used in Sweden*, 1st ed.; SEK Svensk Elstandard: Kista, Sweden, 2018.
26. SS-IEC 60884-1. *Plugs and Socket-Outlets for Household and Similar Purposes—Part 1: General Requirements*, 3rd ed.; SEK Svensk Elstandard: Kista, Sweden, 2013.

27. SS-EN 60309-1. *Plugs, Socket-Outlets and Couplers for Industrial Purposes—Part 1: General Requirements*, 3rd ed.; SEK Svensk Elstandard: Kista, Sweden, 1999.
28. SS-EN 60309-2. *Plugs, Socket Outlets and Couplers for Industrial Purposes—Part 2: Dimensional Interchangeability Requirements for Pin and Contact-Tube Accessories*, 3rd ed.; SEK Svensk Elstandard: Kista, Sweden, 1999.
29. Charging Cable for BEVs with in-line EVSE—Single-Phase Charging Type 2 3.6kW 6 m. Available online: <https://www.deltaco.se/sites/cdn/PublishingImages/Products/EV-1225-01.png?width=260> (accessed on 24 May 2021).
30. SS-EN 62196-1. *Plugs, Socket-Outlets, Vehicle Connectors and Vehicle Inlets—Conductive Charging of Electric Vehicles—Part 1: General Requirements*, 3rd ed.; SEK Svensk Elstandard: Kista, Sweden, 2015.
31. SS-EN 62196-2. *Plugs, Socket-Outlets, Vehicle Connectors and Vehicle Inlets—Conductive Charging of Electric Vehicles—Part 2: Dimensional Compatibility and Interchangeability Requirements for a.c. pin and Contact-Tube Accessories*, 2nd ed.; SEK Svensk Elstandard: Kista, Sweden, 2017.
32. SS-EN 62196-3. *Plugs, Socket-Outlets, Vehicle Connectors and Vehicle Inlets—Conductive Charging of Electric Vehicles—Part 3: Dimensional Compatibility and Interchangeability Requirements for d.c. and a.c./d.c. pin and Contact-Tube Vehicle Couplers*, 1st ed.; SEK Svensk Elstandard: Kista, Sweden, 2015.
33. SS-EN ISO 15118-1:2019. *Road Vehicles—Vehicle to Grid Communication Interface—Part 1: General Information and Use-Case Definition (ISO 15118-1:2019)*, 2nd ed.; SEK Svensk Elstandard: Kista, Sweden, 2019.
34. IEEE Std 1547. *IEEE Standard for Interconnection and Interoperability of Distributed Energy Resources with Associated Electric Power Systems Interfaces*, 2018th ed.; IEEE: Piscataway, NJ, USA, 2018.
35. Hamdaoui, Y.; Maach, A. Smart islanding in smart grids. In Proceedings of the 2016 IEEE Smart Energy Grid Engineering (SEGE), Oshawa, ON, Canada, 21–24 August 2016; pp. 175–180. [\[CrossRef\]](#)
36. SAE-J3068. *Electric Vehicle Power Transfer System Using a Three-Phase Capable Coupler*; SAE International: Warrendale, PA, USA, 2020.
37. Combo2 and Type2 Charging Connectors Side by Side—Type 2 Connector—Wikipedia. Available online: https://en.wikipedia.org/wiki/Type_2_connector#/media/File:Iec-type2-ccs-combo2-and-iec-type2-charging-connectors-side-by-side.jpg (accessed on 29 April 2021).
38. Combo—CCS Socket According to IEC 62196-3 from Khons Technology. Available online: https://ae01.alicdn.com/kf/HTB1BujKainrK1RjSsziq6xptpXaR/EVSE-Combo-2-CCS-Type-2-Socket-IEC-62196-3-Electric-Car-Vehicle-Charging-DC150A-850V.jpg_50x50.jpg_.webp (accessed on 21 May 2021).
39. Chandra Mouli, G.R.; Schijffelen, J.; van den Heuvel, M.; Kardolus, M.; Bauer, P. A 10 kW Solar-Powered Bidirectional EV Charger Compatible With Chademo and COMBO. *IEEE Trans. Power Electron.* **2019**, *34*, 1082–1098. [\[CrossRef\]](#)
40. Jampeethong, P.; Khomfoi, S. An EV quick charger based on CHAdEMO standard with grid-support function. In Proceedings of the 2015 18th International Conference on Electrical Machines and Systems (ICEMS), Pattaya City, Thailand, 25–28 October 2015; pp. 531–536. [\[CrossRef\]](#)
41. SS-EN 60898-1. *Circuit-Breakers for Overcurrent Protection for Household and Similar installations—Part 1: Circuit-Breakers for a.c. Operation*, 2nd ed.; SEK Svensk Elstandard: Kista, Sweden, 2019.
42. Kersten, A.; Liu, Y.; Pehrman, D.; Thiringer, T. Rotor Design of Line-Start Synchronous Reluctance Machine With Round Bars. *IEEE Trans. Ind. Appl.* **2019**, *55*, 3685–3696. [\[CrossRef\]](#)
43. SS-EN 50160. *Voltage Characteristics of Electricity Supplied by Public Distribution Systems*, 3rd ed.; SEK Svensk Elstandard: Kista, Sweden, 2008.
44. Kondo, R.; Schülting, P.; Wienhausen, A.H.; De Doncker, R.W. An Automated Component-Based Hardware Design of a Three-Phase Dual-Active Bridge Converter for a Bidirectional On-Board Charger. In Proceedings of the 2020 IEEE Energy Conversion Congress and Exposition (ECCE), Detroit, MI, USA, 11–15 October 2020; pp. 850–857. [\[CrossRef\]](#)
45. Schülting, P.; Winter, C.; De Doncker, R.W. Design of a High-Frequency Dual-Active Bridge Converter with GaN Devices for an Output Power of 3.7 kW. In Proceedings of the 2018 International Power Electronics Conference (IPEC-Niigata 2018-ECCE Asia), Niigata, Japan, 20–24 May 2018; pp. 388–395. [\[CrossRef\]](#)
46. SS-EN 61557-9. *Electrical Safety in Low-Voltage Distribution Systems up to 1 kV a.c. and 1,5 kV d.c.—Equipment for Testing, Measuring or Monitoring of Protective Measures—Part 9: Equipment for Insulation Fault Location in IT Systems*, 2nd ed.; SEK Svensk Elstandard: Kista, Sweden, 2009.
47. SS-EN 60529. *Degrees of Protection Provided by Enclosures (IP Code)*; SEK Svensk Elstandard: Kista, Sweden, 2014.
48. SS-EN 62262. *Degrees of Protection Provided by Enclosures for Electrical Equipment Against External Mechanical Impacts (IK Code)*, 1st ed.; SEK Svensk Elstandard: Kista, Sweden, 2008.
49. SS-EN 61558-2-4. *Safety of Transformers, Reactors, Power Supply Units and Similar Products For Supply Voltages up to 1100 V—Part 2-4: Particular Requirements and Tests for Isolating Transformers and Power Supply Units Incorporating Isolating Transformers*, 2nd ed.; SEK Svensk Elstandard: Kista, Sweden, 2009.
50. SS-EN 61643-11. *Low-Voltage Surge Protective Devices—Part 11: Surge Protective Devices Connected to Low-Voltage Power Systems—Requirements And Test Methods*, 2nd ed.; SEK Svensk Elstandard: Kista, Sweden, 2013.
51. Meyer, J.; Blanco, A.; Domagk, M.; Schegner, P. Assessment of Prevailing Harmonic Current Emission in Public Low-Voltage Networks. *IEEE Trans. Power Deliv.* **2017**, *32*, 962–970. [\[CrossRef\]](#)

52. Noshahr, J.B.; Meykhosh, M.H.; Kermani, M. Current harmonic losses resulting from first and second generation LED lights replacement with sodium vapor lights in a LV feeder. In Proceedings of the 2017 IEEE International Conference on Environment and Electrical Engineering and 2017 IEEE Industrial and Commercial Power Systems Europe (EEEIC/I CPS Europe), Milan, Italy, 6–9 June 2017; pp. 1–5. [[CrossRef](#)]
53. IEEE Std 519. *IEEE Recommended Practice and Requirements for Harmonic Control in Electric Power Systems*, 2014th ed.; IEEE: Piscataway, NJ, USA 2014.
54. Oberdieck, K.; Gossmann, J.; Bubert, A.; De Doncker, R.W. Common- and Differential-Mode Separators Including the FM-Broadcasting Band. In Proceedings of the PCIM Europe 2018, International Exhibition and Conference for Power Electronics, Intelligent Motion, Renewable Energy and Energy Management, Nuremberg, Germany, 5–7 June 2018; pp. 1–8.
55. Oberdieck, K.; de Doncker, R.W.; Heberling, D. *Measurement and Mitigation of Electromagnetic Emissions of Propulsion Inverters for Electric Vehicles*; Technical Report; Lehrstuhl und Institut für Stromrichtertechnik und Elektrische Antriebe: Aachen, Germany, 2020.
56. Youssef, M.; Roudet, J.; Marechal, Y. Near-field characterisation of power electronics circuits for radiation prediction. In Proceedings of the PESC97, Record 28th Annual IEEE Power Electronics Specialists Conference, Formerly Power Conditioning Specialists Conference 1970-71, Power Processing and Electronic Specialists Conference 1972, St. Louis, MO, USA, 27 June 1997; Volume 2, pp. 1529–1534.
57. Rodriguez, V. Automotive component EMC testing: CISPR 25, ISO 11452-2 and equivalent standards. *IEEE Electromagn. Compat. Mag.* **2012**, *1*, 83–90. [[CrossRef](#)]
58. CISPR 14-1:2020. *Electromagnetic Compatibility—Requirements for Household Appliances, Electric Tools and Similar Apparatus—Part 1: Emission*, 7th ed.; Standard, IEC Test; IEC Geneva Office: Geneva, Switzerland, 2020.
59. CISPR 25:2016. *Vehicles, Boats and Internal Combustion Engines—Radio Disturbance Characteristics—Limits and Methods of Measurement for the Protection of On-Board Receivers*, 4th ed.; Standard, IEC Test; IEC Geneva Office: Geneva, Switzerland, 2016.
60. SS-EN 55014-1. *Electromagnetic Compatibility—Requirements for Household Appliances, Electric Tools and Similar Apparatus—Part 1: Emission*, 4th ed.; SEK Svensk Elstandard: Kista, Sweden, 2017.
61. SS-EN 55025. *Vehicles, Boats, and Internal Combustion Engines—Radio Disturbance Characteristics—Limits and Methods of Measurement for the Protection of On-Board Receivers*, 3rd ed.; SEK Svensk Elstandard: Kista, Sweden, 2017.
62. Hirsch, H.; Jeschke, S.; Wei, L.; Trautmann, M.; Bärenfänger, J.; Maarleveld, M.; Heyen, J.; Darrat, A. Latest development of the national and international EMC-standards for electric vehicles and their charging infrastructure. In Proceedings of the 2015 IEEE International Symposium on Electromagnetic Compatibility (EMC), Dresden, Germany, 16–22 August 2015; pp. 708–713. [[CrossRef](#)]
63. CISPR 16-SER. *Specification for Radio Disturbance and Immunity Measuring Apparatus and Methods*. Standard, IEC Test; IEC Geneva Office: Geneva, Switzerland, 2019.
64. Kersten, A.; Oberdieck, K.; Gossmann, J.; Bubert, A.; Loewenherz, R.; Neubert, M.; Thiringer, T.; Doncker, R.W.D. Measuring and Separating Conducted Three-Wire Emissions From a Fault-Tolerant, NPC Propulsion Inverter With a Split-Battery Using Hardware Separators Based on HF Transformers. *IEEE Trans. Power Electron.* **2021**, *36*, 378–390. [[CrossRef](#)]