



**CHALMERS**  
UNIVERSITY OF TECHNOLOGY

## **Toward Quantum Data Centers: Noise Evaluation of Fiber-Based Interconnects through Distributed Algorithm Emulation**

Downloaded from: <https://research.chalmers.se>, 2026-04-14 12:50 UTC

Citation for the original published paper (version of record):

Elyasi, S., Ahmadian, S., Monti, P. et al (2025). Toward Quantum Data Centers: Noise Evaluation of Fiber-Based Interconnects through Distributed Algorithm Emulation. European Conference on Optical Communication, ECOC.  
<http://dx.doi.org/10.1109/ECOC66593.2025.11263345>

N.B. When citing this work, cite the original published paper.

# Toward Quantum Data Centers: Noise Evaluation of Fiber-Based Interconnects through Distributed Algorithm Emulation

Seyed Navid Elyasi<sup>(1)</sup>, Seyed Morteza Ahmadian<sup>(1)</sup>, Jun Li<sup>(2)</sup>, Paolo Monti<sup>(1)</sup>, Rui Lin<sup>(1)</sup>

<sup>(1)</sup> Department of Electrical Engineering, Chalmers University of Technology, Sweden [elyasi@chalmers.se](mailto:elyasi@chalmers.se)

<sup>(2)</sup> School of Electrical and Information Engineering, Soochow University, China

**Abstract** Communication noise from fiber-interconnected distributed quantum systems is quantified through monolithic processor simulations, with experimental results validating this approach as an effective method for evaluating the performance of distributed quantum algorithms. ©2025 The Author(s)

## Introduction

The transformative potential of quantum computing across various fields is widely recognized. Its scalability, on the other hand, is fundamentally limited by the number of qubits that can be integrated onto a single chip, regardless of the physical platform<sup>[1]–[3]</sup>. To address this limitation, the concept of Quantum Data Centers (QDCs) has been introduced, where multiple quantum processing units (QPUs), each with a relatively small number of qubits, are interconnected to enable distributed quantum computing<sup>[4]–[8]</sup>.

In particular, fiber-based interconnected quantum chips offer a scalable path forward by enabling the exchange of quantum information between spatially separated QPUs. However, the communication subsystem introduces a significant challenge in superconducting quantum computing platforms<sup>[9]</sup>. More specifically, the transduction interface is not yet efficient enough in its capabilities, and the optical fiber interconnections between QPUs introduce extra attenuation. Both effects result in QDC solutions yet not technically mature and scalable due to their low fidelity levels compared to their monolithic counterparts.<sup>[10]–[15]</sup>

The understanding of the impact of the communication noise on the fidelity performance offered by distributed quantum computing remains limited primarily due to the lack of experimental platforms

that can systematically evaluate such effects.

Given these barriers, there is a need for a model that can emulate optical fiber-based quantum communication on a single chip, while also allowing for fine-grained control over the noise associated with different interconnection technologies. Such a model should not only be based on the use of real and physical qubits but also provide insights into the efficiency in terms of connection fidelity of using various fiber types and transduction approaches, the scalability of QPUs, and the practical feasibility of different distributed quantum computing approaches.

In this work, we propose a universal model satisfying the above features to simulate fiber-based quantum communication between superconducting QPUs, using a collisional model that is well-suited for studying open quantum systems through unitary operations<sup>[16]</sup>. This model highlights the dominant impact of transduction on the resulting fidelity in the communication setup, clearly identifying it as a bottleneck. It also shows that the effect of optical fibers remains minimal due to their ultra-low-noise characteristics.

## Architecture and system model

We consider a scenario (Fig.1) where superconducting QPUs are interconnected via an optical fiber mesh and transduction to form a QDC. As

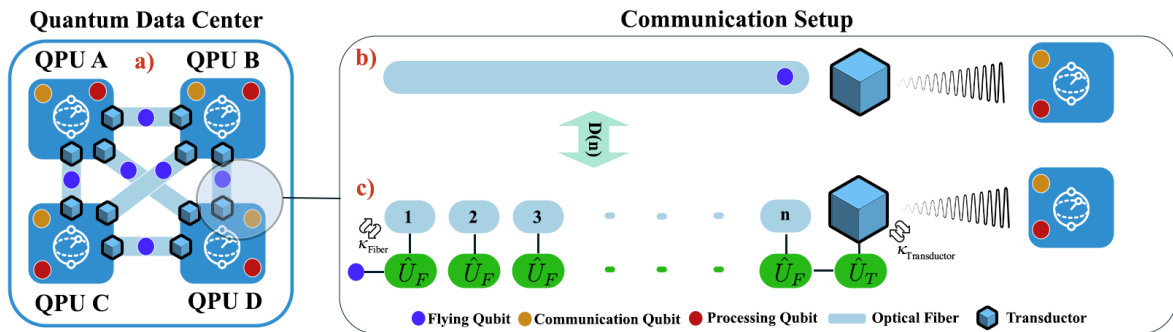

**Fig. 1:** (a) a visual representation of the proposed scenario for simulating noisy entanglement within a quantum QDC, where QPUs are interconnected using a mesh topology; (b) a zoomed-in view of a selected section from (a), highlighting the communication setup; (c) a discretized noise model used to capture the imperfections in the communication channel between QPUs.

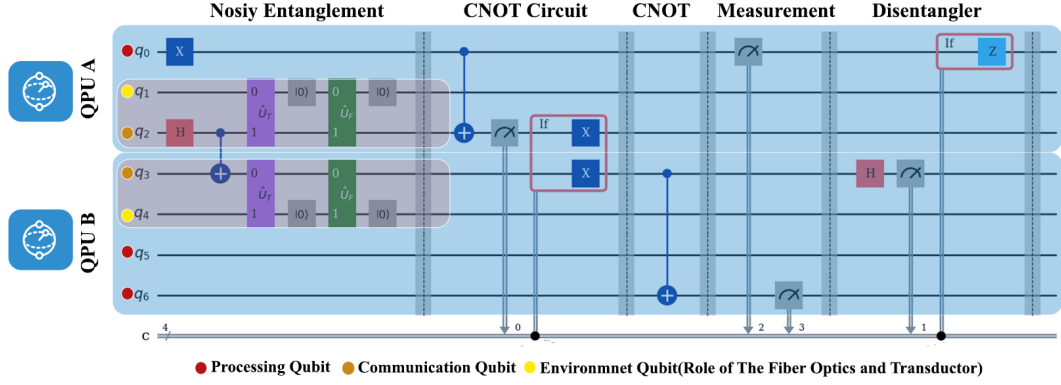

**Fig. 2:** The figure illustrates the circuit representation of a cat-entanglement-based circuit for applying a remote CNOT gate using a noisy controllable entanglement channel. Each blue block represents two groups of qubits, which can be considered as two QPUs, while the red rectangles indicate the noisy entanglement channels that facilitate communication between the QPUs on a single chip.

shown in (Fig.1(a)), each QPU includes: (i) flying qubits (blue circles) which physically carry quantum information and travels between QPUs, (ii) communication qubits (orange circles) which are stationary qubits that prepare the quantum state for transmission, (iii) processing qubits (red circles) that performs quantum computation, and (iv) transducers (blue cubes) which are coupled with communication qubits and converts quantum information from microwave to photons to fly.

Remote entanglement establishment is a fundamental requirement for enabling any form of non-local quantum computation. Such a process relies on communication qubits, flying qubits, and transducers. A key challenge we address is the noise in the communication setup, especially propagation noise affecting the flying qubits, and coupling noise induced by the transducers. In our model, these noise sources are represented as interactions with an environment qubit, as illustrated in Fig.1 (b), allowing their effects to be analyzed.

To simulate the execution of distributed quantum circuits, one must generate a controllable, noisy entanglement between qubits on a single chip, mimicking the behavior of remote entanglement under realistic communication conditions. To handle this (Fig.1.(c)), we adopt a collisional model that discretizes the optical fiber and the interaction time in smaller segments, which are uncorrelated. Each segment of the optical fiber is coupled to the flying qubit moving inside with a constant  $\kappa_{Fiber}$  (calculated based on the attenuation rate of various available optical fibers). The flying qubit interacts with each one of the discretized fiber segments with a unitary operation  $\hat{U}_F$  (Fig.1(c)). Additionally, the transduction is modeled as another segment in which the coupling strength is denoted as  $\kappa_{Transductor}$ . The flying qubit interacts with the transduction with a unitary operation  $\hat{U}_T$ .

### Implementation

The proposed model supports any quantum circuit but centers on implementing a remote CNOT (Cat-CNOT) between processing qubits across two QPUs (QPU A:  $q_0, q_2$ ; QPU B:  $q_3, q_5, q_6$ ; blue rectangles in Fig.2). This requires forming a tunable, noisy entangled link via communication qubits (red rectangles), which are implemented using IBM quantum devices for their compatibility with Qiskit<sup>[17]</sup>. However, these systems lack support for non-unitary operations, which prevents the direct simulation of controlled noise injection<sup>[18]</sup>.

To address this, we adopt a collisional model<sup>[16],[19]</sup> which enables adjustable entanglement fidelity through sequential interactions with uncorrelated auxiliary qubits (yellow circles in Fig.2), allowing to model the environmental effects specific of the fiber and the transduction as shown in Fig.1(c). The state evolution after  $n$  collisions is given by  $\hat{\rho}_n = \hat{U}_n \dots \hat{U}_1 \hat{\rho}_A \hat{U}_1^\dagger \dots \hat{U}_n^\dagger$ , and the reduced state in either QPU becomes  $\rho_n^B = \text{Tr}_{E_n, \dots, E_1} [\hat{\rho}_n]$ . Each  $\hat{U}_j = e^{-i\hat{H}_j/\hbar}$  evolves under an amplitude-damping Hamiltonian  $\hat{H}_j = \kappa (\hat{\sigma}^+ \otimes \hat{\sigma}^{-E_j} + \hat{\sigma}^- \otimes \hat{\sigma}^{+E_j})$ , where  $\kappa$  varies for fiber ( $\kappa_{Fiber}$ ) and transduction ( $\kappa_{transductor}$ ) segments.

Initially, Hadamard and CNOT gates entangle the communication qubits (Fig.2), followed by interactions with the environment qubits: one gate  $\hat{U}_T$  for transduction and multiple  $\hat{U}_F$  gates for each discretized fiber segment. To enforce a Markovian process and conserve qubits, the environment qubits are reset to  $|0\rangle$  between steps (gray rectangles), ensuring uncorrelated dynamics.

Once a noisy entanglement is formed, the remote CNOT executes with QPU A's qubit ( $q_0$ ) as control and QPU B's ( $q_6$ ) as target, followed by measurement and disentanglement. To relate this process to physical distance, we define  $D(n) = \frac{\gamma n}{\alpha}$ , linking interaction steps to QPU separation via coupling strength  $\gamma = \kappa^2$  and fiber attenuation constant  $\alpha$ .

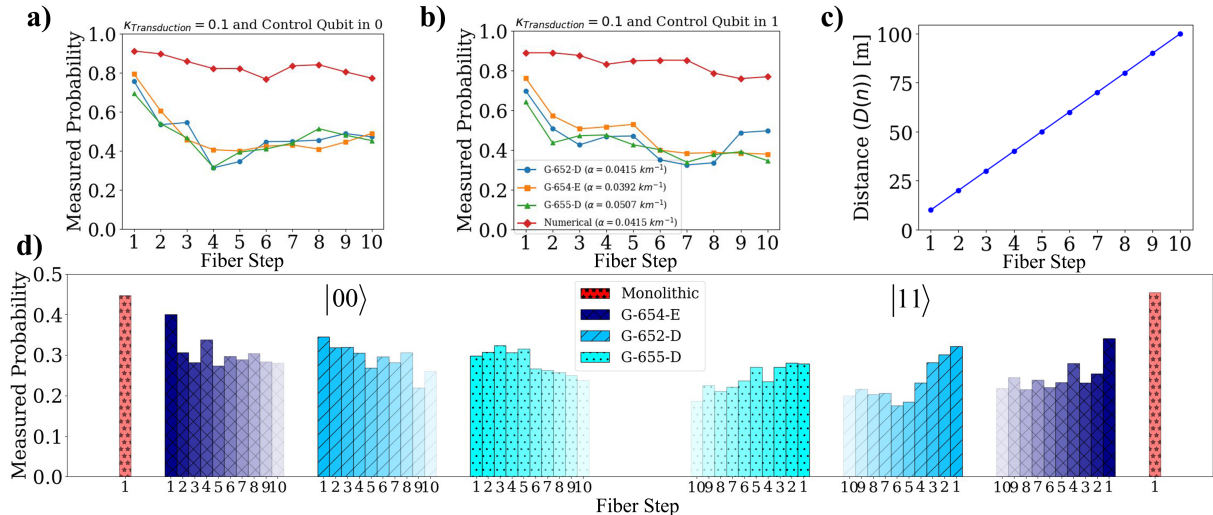

**Fig. 3:** Success probabilities of the remote CNOT gate when the Control Qubit in 0 (a) and 1 (b). Mapping between the number of optical fiber segments and their corresponding physical distance (c). Bell state generation in monolithic and distributed setups using the remote CNOT gate across the same set of optical fibers (d).

## Results

Experiments are run on the `ibm-brisbane` backend. Each data point in Fig.3 is based on 4096 shots per configuration across all subfigures. We evaluate three fiber types (i.e., G-652-D, G-654-D, and G-655-D) with attenuation constants ( $\alpha$ ) equal to 0.0415, 0.0392, and 0.0507  $km^{-1}$ , respectively. Using these values and the distance-mapping formula, we calculated the value of  $\kappa_{Fiber}$  for each fiber, ranging from 0 to 100 meters with a step size of 10 meters (Fig.3(c)), which mimics an intra-QDC environment. For the transduction process, we assume  $\kappa_{Transduction} = 0.1$ , an optimistic yet practical value. Notably, as a valuable point of our model, all the results indicate the full Cat-CNOT process—post-communication and algorithm initialization. We used the same coupling map across all experiments to ensure consistency and make a fair comparison between the results.

Fig.3(a) and Fig.3(b) show the results of applying a remote CNOT gate with the control qubit initialized to  $|0\rangle$  and  $|1\rangle$ , respectively. In both cases, we observe an immediate  $\sim 20\%$  drop in the fidelity of the target states— $|00\rangle$  and  $|11\rangle$ —even before the first fiber step, attributed to the transduction stage. This drop aligns with expectations for current transduction technologies. Steps 1 through 10 simulate a segmented optical fiber. The fidelity decreases across all three fiber types as the steps increase. Superimposed on this trend are fluctuations caused by inherent hardware noise, which manifest as irregularities in the plots. These reflect realistic conditions in physical QPUs, where gate and qubit errors persist regardless of whether connections are direct or remote.

Apart from experimental results shown in Fig.3(a) and (b), to highlight the effects of these device-level imperfections, we also performed numerical simulations (red curves in Fig.3(a) and

Fig.3(b)) using IBM's updated noise parameters, refreshed every 30 minutes. The results highlight the non-deterministic behavior of physical qubits and the limitations of numerical simulations.

To relate these results to fiber-interconnected scale, i.e., propagation distances, we use the mapping plot in Fig.1(c), converting each step in Fig.3(a), (b), and (d) into corresponding physical distance based on initial noise parameters ( $\alpha$  and  $\kappa$ ). As seen in Fig.2 to prove the flexibility of our model into larger circuits, we further extend the model to a practical use case, assuming QPUs placed 10 meters apart with the same  $\kappa_{Transduction}$ . Here, the remote CNOT is used to generate a Bell state between  $q_0$  (QPU A) and  $q_6$  (QPU B). Fig.3(d) compares the probabilities of obtaining states  $|00\rangle$  and  $|11\rangle$  in this remote scenario versus a monolithic execution. As expected, the distributed circuit exhibits a noticeable drop in fidelity before the first step, coming from transduction. These experiments are repeated across the three fiber types. As  $\alpha$  increases, we observe a slight but consistent degradation in the likelihood of achieving the correct outcomes.

## Conclusions

In this work, we propose a realistic noise modeling framework for fiber-interconnected QPUs, incorporating propagation noise and transducer errors using a collisional approach. Results reveal that transducer errors dominate the noise in degrading the fidelity of the remote quantum gate. The model provides a powerful tool to quantify fidelity loss in practical scenarios and facilitates the investigation into the scalability of QDCs, thereby contributing to the theoretical foundation and experimental validation of QDC architectures.

## Acknowledgements

This work is supported by the project “DIGITAL-2022-QCI-02-DEPLOY-NATIONAL” (Project number: 101113375 — NQCIS) funded by the EU together with Vinova and WACQT. Additional support is provided by VR and GENIE. We thank Chalmers Next Labs for providing a premium account and support for the IBM Quantum platforms.

## References

- [1] F. Sebastiano, “Scalable read-out schemes for qubits”, *Nature Electronics*, vol. 2, pp. 215–216, 2019. DOI: 10.1038/s41928-019-0263-9. [Online]. Available: <https://www.nature.com/articles/s41928-019-0263-9>.
- [2] F. Battistel *et al.*, “Optimizing resource efficiencies for scalable full-stack quantum computers”, *PRX Quantum*, vol. 4, p. 040319, 2023. DOI: 10.1103/PRXQuantum.4.040319. [Online]. Available: <https://journals.aps.org/prxquantum/abstract/10.1103/PRXQuantum.4.040319>.
- [3] M. Sarovar, T. Proctor, K. Rudinger, K. Young, E. Nielsen, and R. Blume-Kohout, “Detecting crosstalk errors in quantum information processors”, *Quantum*, vol. 4, p. 321, 2020. DOI: 10.22331/q-2020-09-11-321.
- [4] J. Liu and L. Jiang, “Quantum data center: Perspectives”, *IEEE Network*, vol. 38, no. 5, pp. 160–166, 2024. DOI: 10.1109/MNET.2024.3397836.
- [5] J. Liu, C. T. Hann, and L. Jiang, “Data centers with quantum random access memory and quantum networks”, *Physical Review A*, vol. 108, no. 3, p. 032610, 2023. DOI: 10.1103/PhysRevA.108.032610.
- [6] H. Shapourian, E. Kaur, T. Sewell, *et al.*, “Quantum data center infrastructures: A scalable architectural design perspective”, *arXiv preprint*, 2025. eprint: 2501.05598. [Online]. Available: <https://arxiv.org/abs/2501.05598>.
- [7] H. Buhrman and H. Röhrig, “Distributed quantum computing”, in *International Symposium on Mathematical Foundations of Computer Science*, ser. Lecture Notes in Computer Science, vol. 2572, Springer, 2003, pp. 1–20. DOI: 10.1007/3-540-36577-2\_1. [Online]. Available: [https://doi.org/10.1007/3-540-36577-2\\_1](https://doi.org/10.1007/3-540-36577-2_1).
- [8] A. S. Cacciapuoti, M. Caleffi, F. Tafuri, F. S. Cataliotti, S. Gherardini, and G. Bianchi, “Quantum internet: Networking challenges in distributed quantum computing”, *IEEE Network*, vol. 34, no. 1, pp. 137–143, 2019. DOI: 10.1109/MNET.2019.8734107. [Online]. Available: <https://doi.org/10.1109/MNET.2019.8734107>.
- [9] K. Campbell, A. Lawey, and M. Razavi, “Quantum data centres: A simulation-based comparative noise analysis”, *Quantum Science and Technology*, vol. 10, no. 1, p. 015052, 2024. DOI: 10.1088/2058-9565/10/1/015052. [Online]. Available: <https://doi.org/10.1088/2058-9565/10/1/015052>.
- [10] M. Mirhosseini, A. Sipahigil, M. Kalaei, and O. Painter, “Quantum transduction of optical photons from a superconducting qubit”, *Nature*, vol. 588, pp. 599–603, 2020. DOI: 10.1038/s41586-020-3038-6. [Online]. Available: <https://doi.org/10.1038/s41586-020-3038-6>.
- [11] —, “Superconducting qubit to optical photon transduction”, *Nature*, vol. 588, no. 7839, pp. 599–603, 2020. DOI: 10.1038/s41586-020-3038-6. [Online]. Available: <https://doi.org/10.1038/s41586-020-3038-6>.
- [12] C. L. Rau, A. Kyle, A. Kwiatkowski, *et al.*, “Entangling superconducting qubits over optical fiber—towards optimization and implementation”, in *Proceedings of the 2022 IEEE International Conference on Quantum Computing and Engineering (QCE)*, IEEE, 2022, pp. 771–772. DOI: 10.1109/QCE53715.2022.00099. [Online]. Available: <https://doi.org/10.1109/QCE53715.2022.00099>.
- [13] J. Rochman, T. Xie, J. G. Bartholomew, K. Schwab, and A. Faraon, “Microwave-to-optical transduction with erbium ions coupled to planar photonic and superconducting resonators”, *Nature Communications*, vol. 14, no. 1, p. 1153, 2023. DOI: 10.1038/s41467-023-36656-3. [Online]. Available: <https://doi.org/10.1038/s41467-023-36656-3>.
- [14] M. Xu, C. Li, Y. Xu, and H. X. Tang, “Light-induced microwave noise in superconducting microwave-optical transducers”, *Physical Review Applied*, vol. 21, no. 1, p. 014022, 2024. DOI: 10.1103/PhysRevApplied.21.014022. [Online]. Available: <https://doi.org/10.1103/PhysRevApplied.21.014022>.
- [15] A. Almanakly, B. Yankelevich, M. Hays, *et al.*, “Deterministic remote entanglement using a chiral quantum interconnect”, *Nature Physics*, 2025. DOI: 10.1038/s41567-025-02811-1. [Online]. Available: <https://www.nature.com/articles/s41567-025-02811-1>.
- [16] S. N. Elyasi, M. Rossi, and M. G. Genoni, “Experimental simulation of daemonic work extraction in open quantum batteries on a digital quantum computer”, *Quantum Science and Technology*, 2024.
- [17] A. Javadi-Abhari, M. Treinish, K. Krsulich, *et al.*, “Quantum computing with qiskit”, *arXiv preprint arXiv:2405.08810*, 2024. [Online]. Available: <https://arxiv.org/abs/2405.08810>.
- [18] E. Ferraro, M. Fanciulli, and M. D. Michielis, “Controlled-not gate sequences for mixed spin qubit architectures in a noisy environment”, *Quantum Information Processing*, vol. 16, no. 11, p. 277, 2017. DOI: 10.1007/s11128-017-1729-1. [Online]. Available: <https://doi.org/10.1007/s11128-017-1729-1>.
- [19] N. K. Bernardes, A. R. R. Carvalho, C. H. Monken, and M. F. Santos, “Environmental correlations and markovian to non-markovian transitions in collisional models”, *Physical Review A*, vol. 90, no. 3, p. 032111, 2014. DOI: 10.1103/PhysRevA.90.032111. [Online]. Available: <https://doi.org/10.1103/PhysRevA.90.032111>.